

Type 3271 Pneumatic Actuators

1000, 1400-120, 2800 and 2x 2800 cm²



Application

Linear actuators particularly suitable for attachment to SAMSON Series 240, 250, 280 and 290 Valves

Actuator area	1000 to 2800 cm²
Travel	Up to 160 mm

The Type 3271 Pneumatic Actuators are diaphragm actuators with rolling diaphragm and internal compression springs.

Special features

- Powerful thrust at high stroking speed
- Low friction
- Various bench ranges by varying the number of springs or their compression
- No special tools required to change the bench range or reverse the direction of action (also tandem actuator and version with handwheel)
- Permissible operating temperatures from -60 to +90 °C
- Female thread on the top diaphragm case

Versions

- **Type 3271 · Pneumatic actuator** (Fig. 1 and Fig. 2), 1000, 1400-120 and 2800 cm² actuator areas
- **Type 3271 · Pneumatic tandem actuator** (Fig. 3), 2 x 2800 cm² actuator area
- **Type 3271 · Actuator with travel stop** (Fig. 4), minimum and maximum travel mechanically adjustable with 1000 cm² actuators with 60 mm travel, 1400 cm² with 120 mm travel and 2800 cm² actuators as well as with tandem actuators with 2 x 2800 cm²

Further versions

- **Type 3273 Side-mounted Handwheel** · See Data Sheet ▶ T 8312
- **Versions for other control media** (e.g. water) available on request.

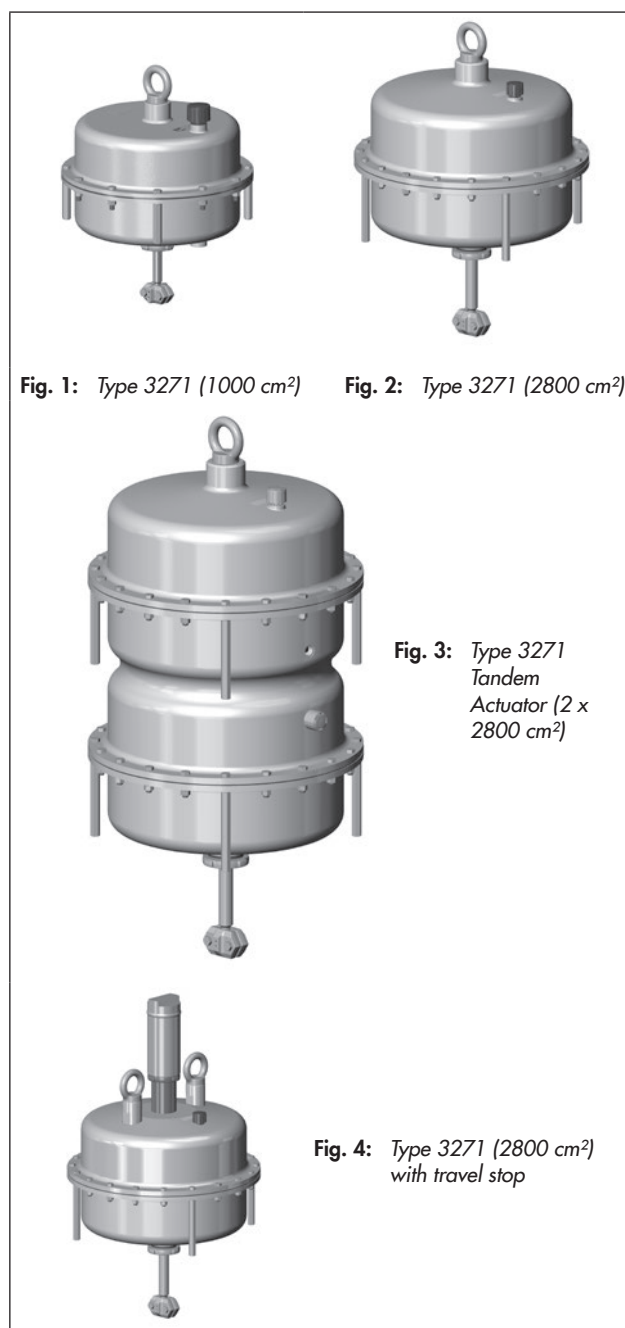

Fig. 1: Type 3271 (1000 cm²)

Fig. 2: Type 3271 (2800 cm²)

Fig. 3: Type 3271 Tandem Actuator (2 x 2800 cm²)

Fig. 4: Type 3271 (2800 cm²) with travel stop

Principle of operation

The signal pressure p_{st} creates the force $F = p_{st} \cdot A$ at the diaphragm surface A which is opposed by the springs (10) in the actuator. The bench range is determined by the number of springs used and their compression, taking into account the rated travel. The travel H is proportional to the signal pressure p_{st} . The direction of action of the actuator stem (7) depends on how the springs are installed in the actuator.

The stem connector (26) connects the actuator stem (7) with the plug stem of the valve.

The adjustable **mechanical travel stop** (Fig. 9) is suitable for actuators with 1000, 1400-120 and 2800 cm² actuator areas as well as tandem actuators. Using the travel stop, the actuator travel can be limited by up to 50 % in both directions (actuator stem extends or retracts) and permanently adjusted.

The tandem actuator (Fig. 7) contains two coupled diaphragms; they produce a positioning force that is twice as high as the force of a single actuator.

Direction of action

Actuators are available with the following directions of action:

- **Actuator stem extends (FA):** the springs cause the actuator stem to move to the lower end position when the diaphragm is relieved of pressure or when the supply air fails.
- **Actuator stem retracts (FE):** the springs cause the actuator stem to retract when the diaphragm is relieved of pressure or when the supply air fails.

Throttling or on/off service

The Type 3271 Pneumatic Actuators are designed for a maximum supply pressure of 6 bar when used for throttling service.

In on/off service and special actuators for throttling service, the supply pressure must be limited.

For the direction of action "actuator stem retracts (FE)", the permissible supply pressure must not exceed the upper bench range value by more than 3 bar:

Signal pressure range	Fail-safe action	Max. supply pressure
0.2 to 1.0 bar	Actuator stem retracts	4 bar
0.4 to 2.0 bar		5 bar
0.6 to 3.0 bar		6 bar

With the direction of action "actuator stem extends" and travel stop, the supply pressure must not exceed the upper bench range value by more than 1.5 bar.

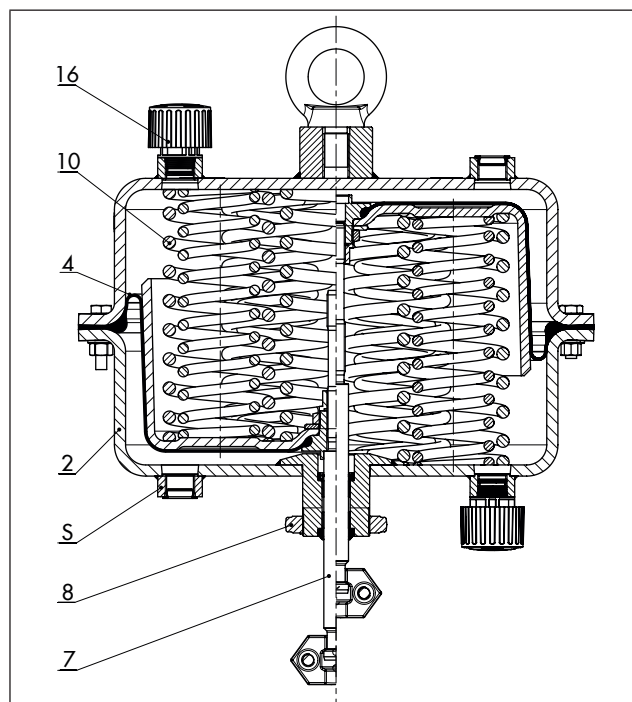

Fig. 5: Type 3271 with 1000 cm² actuator area

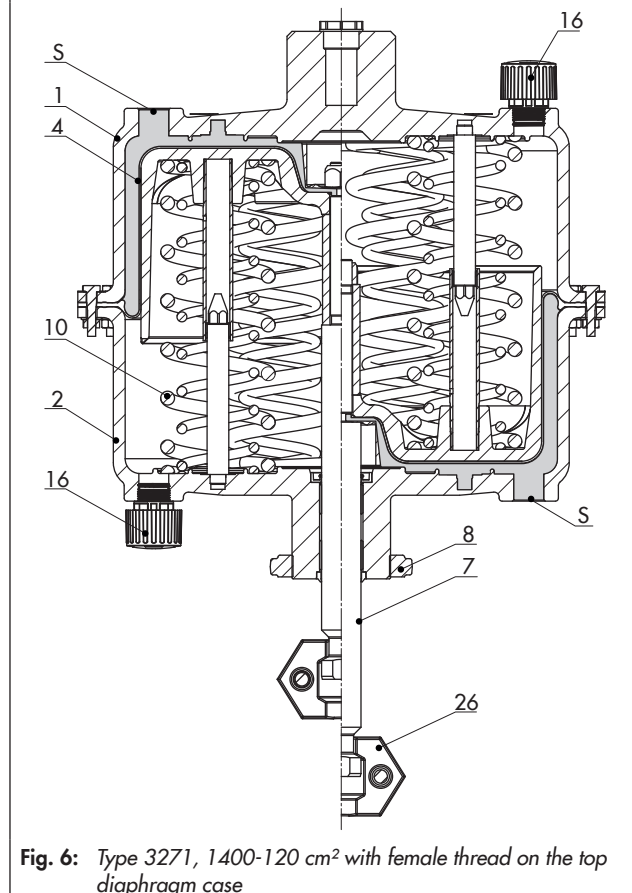

Fig. 6: Type 3271, 1400-120 cm² with female thread on the top diaphragm case

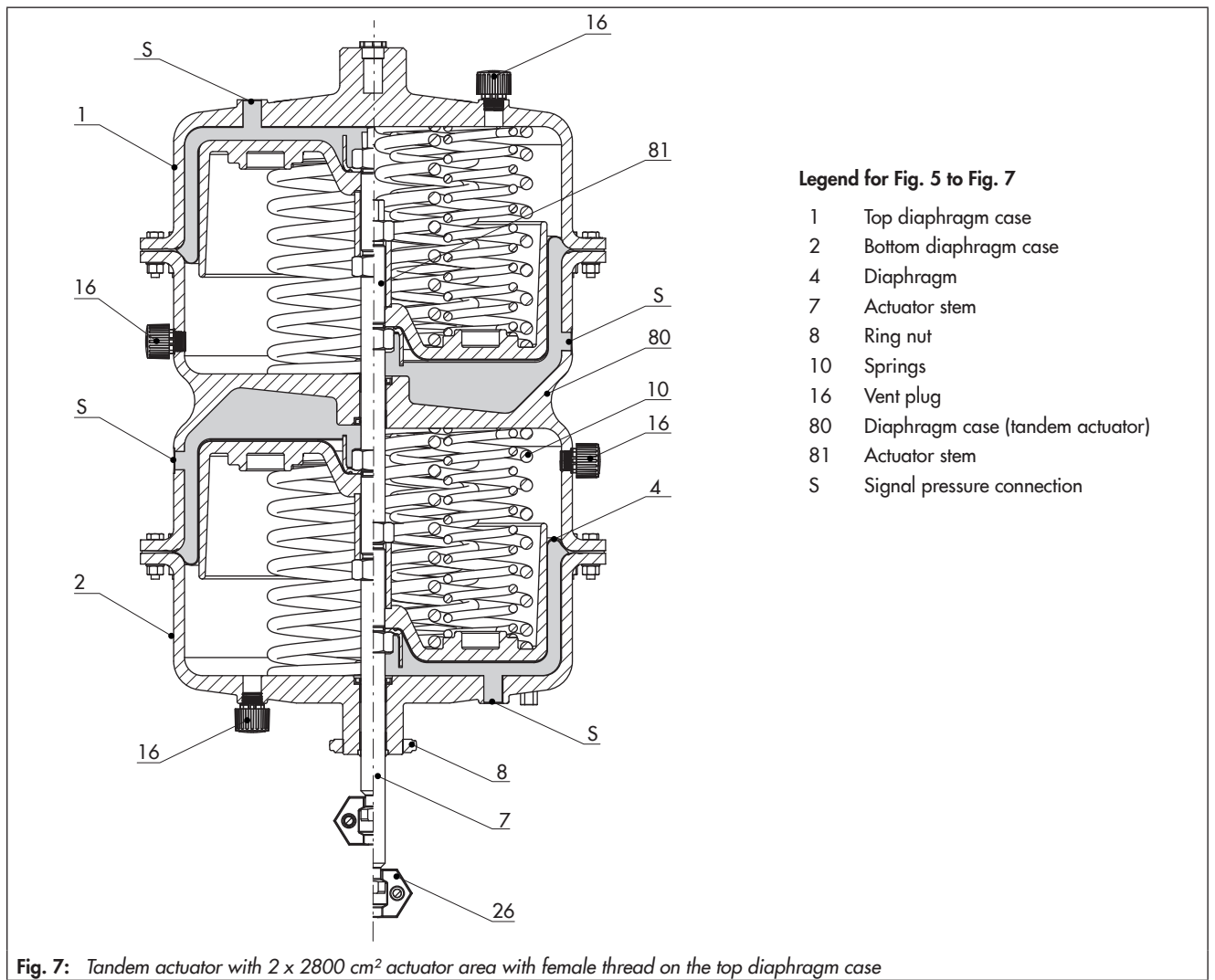

Table 1: Technical data**Table 1.1: Type 3271 Pneumatic Actuator**

Version	cm ²	1000	1400-120	2800	2 x 2800
Max. supply pressure		6 bar ¹⁾			
Permissible ambient temperatures		Diaphragm material NBR: -35 to +90 °C ^{2) 3)}			
		Diaphragm material PVMQ: -60 to +90 °C ³⁾			
Compliance		EAC			
Materials					
Actuator stem		1.4548.4	1.4404	1.4548.4	
Actuator stem sealing		NBR	NBR		
		EPDM	PVMQ		
Housing and associated ambient temperature	1.0982 S460 MC Sheet steel, painted ≥ -60 °C	EN-JS1030 (GGG-40) ⁴⁾ Spheroidal graphite iron Max. 100 °C			
		1.5638/A352 LC3 Painted cast steel ≥ -60 °C			

¹⁾ Observe supply air restrictions.

²⁾ In on/off service, lowest temperature restricted to -20 °C

³⁾ Install vent plug (▶ AB 07) for temperatures below -20 °C.

⁴⁾ Not with diaphragm material PVMQ

Table 1.2: Versions

Implementation	1000 cm ²	1400-120 cm ²	2800 cm ²	2 x 2800 cm ²
Mechanical travel stops on both sides	•	•	•	•
Additional handwheel, 50 kN	•	-	-	-
Additional handwheel, 80 kN	•	• ¹⁾	• ¹⁾ (max. 3 bar)	-
Additional handwheel, 150 kN	-	•	•	•
Throttling or on/off service	•	•	•	•

¹⁾ Max. 60 mm

Table 2: Bench ranges for 1000, 1400 and 2800 cm² pneumatic actuators

All pressures in bar (gauge) · Pretensioned springs cannot be used with the direction of action "actuator stem retracts" for Series 240, 250 and 280 Valves.

Actuator type	Actuator area in cm ²	Rated travel in mm	Travel volume at rated travel in dm ³	Dead volume in dm ³	Max. travel in mm ¹⁾	Bench range in bar (Signal pressure range at rated travel)	Add. possible spring compression in %	Operating range with spring compression in bar	No. of springs	Spring force at 0 mm travel in kN ²⁾	Spring force at rated travel in kN ²⁾	Thrust in kN ²⁾ at rated travel and supply pressure in bar of					
												1.4	2.0	3.0	4.0	5.0	6.0
Type 3271	1000	60	6.4	6.1	80	0.4 to 2.0	25	0.8 to 2.4	6	4	20	-	10	20	30	-	
						0.6 to 3.0		1.2 to 3.6	9	6	30	-	-	10	20	30	
						0.8 to 2.8		1.3 to 3.3	9	8	28	-	2.0	12	22	-	
						1.0 to 3.2 ¹⁾		1.5 to 3.7	10	10	32	-	-	8	18	28	
¹⁾ With fail-safe action "actuator stem extends" only																	
Type 3271	1400	120	16.6	4.7	130	0.4 to 1.2	0 ³⁾	-	3	5.6	16.8	2.8	11.2	25.2	39.2	53.2	67.2
						0.8 to 2.4			6	11.2	33.6	-	-	8.4	22.4	36.4	50.4
						1.0 to 3.0			9	14	42	-	-	-	14	28	42
						1.2 to 3.6			12	16.8	50.4	-	-	-	5.6	19.6	33.6
Type 3271	2800	120	33	16.5	160	0.2 to 1.0	25	0.4 to 1.2	3	5.6	28	11.2	28	56	84	112	140
						0.4 to 2.0		6	11.2	56	-	28	56	84	112		
						0.5 to 2.5		9	14	70	-	14	42	70	98		
						0.6 to 3.0		12	16.8	84	-	28	56	84			
						0.8 to 1.7	25	1.0 to 1.9	6	22.4	47.6	-	8.4	36.4	64.4	92.4	120.4
						0.9 to 2.2		9	25.2	61.6	-	22.4	50.4	78.4	106.4		
						1.0 to 2.7		12	28.0	75.6	-	8.4	36.4	64.4	92.4		
						1.1 to 2.3	25	1.4 to 2.6	6	30.8	64.4	-	19.6	47.6	75.6	104	
						1.2 to 2.8		9	33.6	78.4	-	5.6	33.6	61.6	89.6		
						1.3 to 3.3		12	36.4	92.4	-	19.6	47.6	75.6			
Type 3271	2 x 2800	120	66	33	160	0.2 to 1.0	25	0.4 to 1.2	6	11.2	56	22.4	56	112	168	224	280
						0.4 to 2.0		12	22.4	112	-	56	112	168	224		
						0.5 to 2.5		18	28	140	-	28	84	140	196		
						0.6 to 3.0		24	33.6	168	-	56	112	168			
						0.8 to 1.7	25	1.0 to 1.9	12	44.8	95.2	-	16.8	74.8	128.8	184.8	240.8
						0.9 to 2.2		18	50.4	123.2	-	44.8	100.8	156.8	212.8		
						1.0 to 2.7		24	56.0	151.2	-	16.8	72.8	128.8	184.8		
						1.1 to 2.3	25	1.4 to 2.6	12	61.6	128.8	-	39.2	95.2	151.2	208	
						1.2 to 2.8		18	67.2	156.8	-	11.2	67.2	123.2	179.2		
						1.3 to 3.3		24	72.8	184.8	-	39.2	95.2	151.2			

- ¹⁾ Based on lower bench range value, not taking zero travel (to unseat the plug) into account (see Table 3).
²⁾ The forces specified relate to the bench range.
³⁾ The springs are already preloaded.

Table 3: Dimensions and weights for versions without handwheel

Actuator	Type	3271			
		Refer to	Fig. 1 · Fig. 8	Fig. 10	Fig. 2 · Fig. 10
Actuator area	cm ²	1000	1400-120	2800	2 x 2800
Height	H	313	470	585	1085
	H4 _{rated} FA	165	285	315	
	H4 _{max} FA	169	288	325	
	H4 _{max} FE	185	315	355	
	H6	54	85	85	
	H7 ¹⁾	90	128	128	
Travel limitation	H8	220	500	500	
Diameter	ØD	462	534	770	
	ØD2	22	40	40	
Ød (thread)		M60x1.5	M100x2	M100x2	
Pneumatic connection (optional)	a	G ¾/¾ NPT	G 1/1 NPT	G 1/1 NPT	
	a2	–		–	
Weight [kg]					
Without handwheel		80	175	450	950

¹⁾ Height of eyebolt according to DIN 580. Height of the swivel lifting hook may differ.

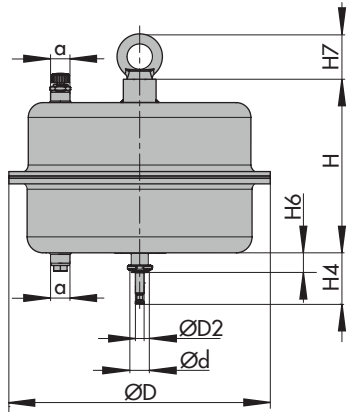

Fig. 8: Type 3271, 1000 cm²

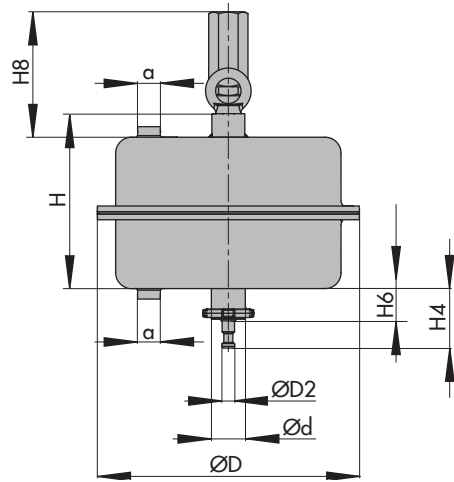

Fig. 9: Type 3271, 1000 cm² with mechanical travel stop

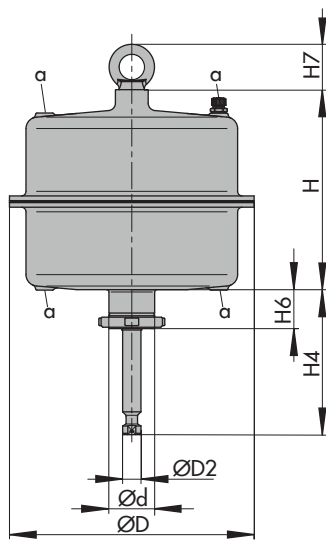

Fig. 10: Type 3271, 1400-120 cm²

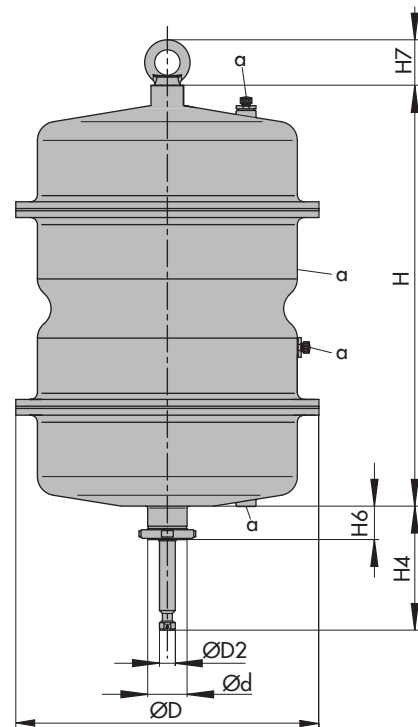

Fig. 11: Type 3271 as tandem actuator

Accessories

The pneumatic actuators with 1000, 1400-120, 2800 und 2 x 2800 cm² actuator area have a female thread on the top diaphragm case to allow an eyebolt or swivel lifting hook to be screwed into it. The eyebolt can be used to vertically lift the actuator and is included in the scope of delivery. The swivel lifting hook is designed for setting a control valve assembly upright or for lifting the actuator without valve. The swivel lifting hook can be ordered (accessories).

Actuator area	Item no.	
	Ring bolt (DIN 580)	Swivel lifting hook
1000 cm ²	8325-0135	8442-1018
1400-120 cm ² 2800 cm ² 2x 2800 cm ²	8325-1101	8442-1019

Ordering text

Actuator	Type 3271
Actuator area	... cm ²
Travel	... mm
Optional	Travel limitation Tandem actuator
Signal pressure range	... bar
Direction of action	Actuator stem extends (FA) Actuator stem retracts (FE)
Signal pressure connection	G .../... NPT
Rolling diaphragm	NBR/PVQM/EPDM (1000 cm ² only)

List of documentation

Device type	Actuator area in cm ²	Data sheet	Mounting and operating instructions
Types 3271 and 3277 Pneumatic Actuators	120	▶ T 8310-1/4/5/6	▶ EB 8310-1
	240 · 350 · 700		▶ EB 8310-6
	175v2 · 350v2 · 750v2		▶ EB 8310-5
	355v2		▶ EB 8310-4
Type 3271 Pneumatic Actuator	1000	Included in this data sheet	▶ EB 8310-2
	1400-120 · 2800 · 2 x 2800		▶ EB 8310-7
	1400-60	▶ T 8310-3	▶ EB 8310-3
	1400-250	▶ T 8310-8	▶ EB 8310-8

Specifications subject to change without notice



SAMSON AG · MESS- UND REGELTECHNIK
Weismüllerstraße 3 · 60314 Frankfurt am Main, Germany
Phone: +49 69 4009-0 · Fax: +49 69 4009-1507
samson@samson.de · www.samson.de

T 8310-2/7 EN

2018-04-25 · English