

# Rosemount™ 5900S Radar Level Gauge

High performance level measurement for tank gauging systems



- Get highest certified custody transfer accuracy of 0,5 mm for precise monitoring of bulk liquid assets
- Increase safety with third party certified IEC 61508 SIL 2 or SIL 3 capability
- Enable independent back-up level measurement and overfill prevention with innovative 2-in-1 functionality
- Benefit from convenient and safe installation with 2-wire IS bus power supply
- Include wired and/or wireless data transmission
- Measure in all bulk storage tank types and products, ranging from liquefied gases, light products, crude oil and bitumen

# Improve measurement accuracy, plant efficiency and safety

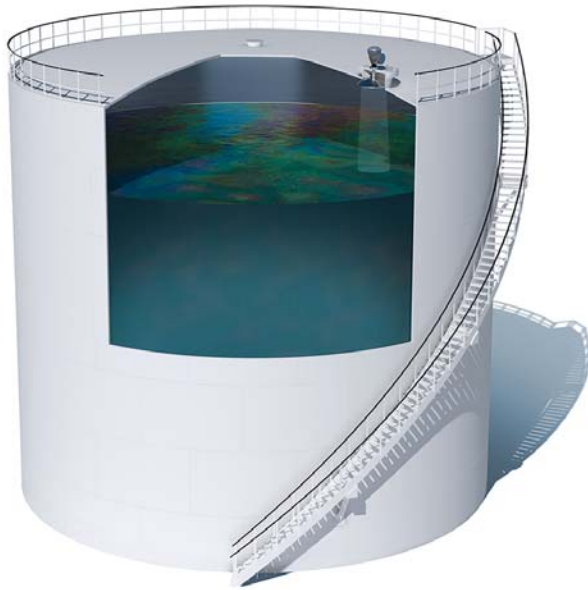

## Highest level precision for your bulk liquid storage tanks

The Rosemount 5900S radar gauge with its 0.5 mm instrument accuracy reduces level measurement uncertainty to a minimum. It enhances your storage operation by providing:

- Certified custody transfer accuracy according to OIML and other legal metrological authorities
- Better inventory management
- Reliable loss control data

The Rosemount 5900S is normally combined with high precision multi-spot temperature sensors. This enables accurate net volume calculations according to API and other standards.

## Make operations more efficient

- No moving parts and no contact with the liquid gives increased reliability and fewer interruptions
- Most Rosemount 5900S antenna types are installed with the tanks in operation
- Emerson™ wireless solution can drastically reduce installation cost and give you access to remote tanks
- The Rosemount 5900S gauge is available with antennas for all bulk liquid storage applications and tank types

## Taking overfill safety to a higher level

- Innovative 2-in-1 feature with two radar gauges in one housing for independent level and overfill measurement
- SIL 2 and SIL 3 certified safety according to IEC 61508
- Enables API 2350 compliant solutions

### Contents

Ordering Information .....	4	Product Certifications .....	26
Specifications .....	20	Dimensional Drawings .....	32

# Get complete level and inventory information

The Rosemount 5900S is a premium non-contact radar level gauge, suitable for tank terminals and refineries. It is integrated into a high performance tank gauging system including average temperature measurement, free water level, pressure and API standard net volumes. See also Rosemount Tank Gauging [System Data Sheet \(SDS\)](#).

Data is displayed locally and on a host computer or via the TankMaster™ inventory software in the control room.

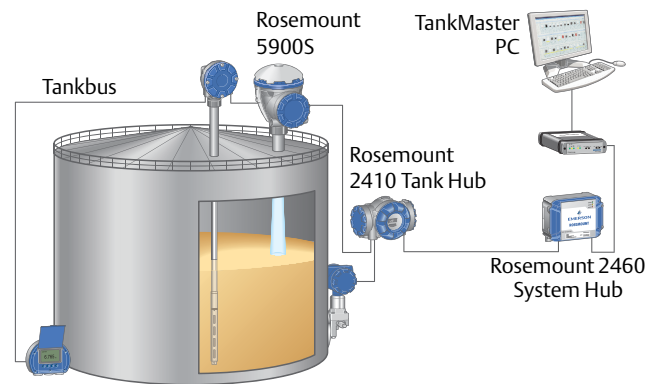

## SIL safety functions

Rosemount 5900S is certified SIL 2 and SIL 3 capable for use in overfill prevention systems via outputs from the Rosemount 2410 Tank Hub connected to the gauge. The alarm signal can be connected to an Emergency Shut-down System (ESD)/Automatic Overfill Prevention System (AOPS).

SIL 2 is achieved via the 4-20 mA output or via a safety relay. SIL 3 requires a Rosemount 5900S with the 2-in-1 option. The SIS functionality activates a separate alarm loop at a preset liquid level and triggers the safety relay or analog output in the tank hub.

## 2-in-1 gauge for cost-efficient level measurement redundancy

The Rosemount 5900S gauge can be delivered with two independent units in one housing. This unique 2-in-1 solution gives you one primary and one backup level unit, or one level gauge plus an independent radar based High-High level alarm. It means that the single Rosemount 5900S 2-in-1 can serve as a safety certified level device in two independent protection layers (i.e. BPCS and SIS).

The 2-in-1 solution enables real-time delta verification by configuring the transmitter to compare signals on both units.

The 2-in-1 solution uses only one tank opening, which reduces installation cost.



Rosemount 5900S with two galvanically separated gauges within the same housing (2-in-1 solution).

## Innovative antenna technology

The drip-off design with inclined polished PTFE surfaces on the antenna enables highest performance by reducing condensation from product and water.

The still-pipe gauge uses the Low Loss H01 radar transmission mode. This mode focuses the microwave energy into the center of the pipe, ensuring custody transfer accuracy also in old still pipes with rust and product deposits.



# Ordering Information

## Rosemount 5900S Radar Level Gauge with parabolic antenna



Rosemount 5900S with parabolic antenna is a premium non-contact radar level gauge. It is the first choice for installation on tanks with fixed roofs without a still-pipe. The parabolic antenna can be installed on existing manhole covers and close to the tank wall due to the narrow radar beam and high signal to noise ratio. In certain cases, it can be used on tanks with floating roofs to measure the distance down to a target plate on the roof.

- Measures all products ranging from light products to heavy fuel oil, bitumen and asphalt
- Antenna design gives extreme tolerance to product build-up and condensation
- Custody transfer accuracy according to OIML R85:2008
- Certified SIL 2 and SIL 3 capable according to IEC 61508
- 2-in-1 functionality available for redundant level measurement
- Communicates via a 2-wire, low voltage Tankbus for easy and safe installation
- Installation normally with tank in service

**Table 1. Rosemount 5900S Radar Level Gauge with Parabolic Antenna Ordering Information**

Model	Product description
5900S	Radar Level Gauge
<b>Performance class</b>	
P	Premium: ±0.5 mm (0.020 in.) instrument accuracy
<b>Safety certification (SIS)</b>	
3 <sup>(1)</sup>	Certified IEC 61508 SIL 3 capable
5 <sup>(2)</sup>	Certified IEC 61508 SIL 2 capable
F	None. Ready for upgrade to Safety certification (SIS)
0	None
<b>Redundancy</b>	
2	2-in-1: Dual independent radar level gauge electronics
F	None. Ready for upgrade to 2-in-1
1	None. Single radar level gauge electronics
<b>Tankbus: Power and communication</b>	
F	Bus powered 2-wire FOUNDATION™ Fieldbus (IEC 61158)
<b>Hazardous location certification</b>	
I1	ATEX Intrinsic Safety
I2	INMETRO Intrinsic Safety (Brazil)
I4 <sup>(3)</sup>	TIIS Intrinsic Safety (Japan)

**Table 1. Rosemount 5900S Radar Level Gauge with Parabolic Antenna Ordering Information**

I5	FM-US Intrinsic Safety
I6	FM-Canada Intrinsic Safety
I7	IECEx Intrinsic Safety
IM	Technical Regulations Customs Union (EAC) Intrinsic Safety (Russia)
IP <sup>(4)</sup>	KC Intrinsic Safety (South Korea)
NA	None
<b>Custody transfer type approval<sup>(5)</sup></b>	
R <sup>(6)(7)</sup>	OIML R85 edition 2008
A <sup>(6)(7)</sup>	CMI (Czech Republic)
B <sup>(6)(7)</sup>	NMI (Australia)
C <sup>(6)(8)</sup>	PTB Eich (Germany)
E <sup>(6)(7)</sup>	TJA (Estonia)
G <sup>(6)(7)</sup>	GUM (Poland)
I <sup>(7)(9)</sup>	Ministero (Italy)
K <sup>(6)(7)(10)</sup>	GOST (Kazakhstan)
L <sup>(9)(11)</sup>	LNE (France)
M <sup>(7)(9)</sup>	BMS (Belgium)
N <sup>(9)(12)</sup>	NMi (The Netherlands)
Q <sup>(6)(7)</sup>	IPQ (Portugal)
S <sup>(6)(7)(10)</sup>	GOST (Russia)
W <sup>(6)(7)</sup>	METAS (Switzerland)
Y <sup>(6)(7)</sup>	Justervesenet (Norway)
0	None
<b>Level measurement method</b>	
1	10 GHz FMCW radar technology
2	10 GHz FMCW radar technology for the US market
<b>Housing</b>	
A	Standard enclosure, polyurethane-covered aluminum. IP 66/67
<b>Cable entry/Conduit connections</b>	
1	½ - 14 NPT, female thread. (1 plug included)
2	M20 x 1.5 adapters, female thread. (2 adapters and 1 plug included)
G	Metal cable glands (½ - 14 NPT). Min. temperature -20 °C (-4 °F). ATEX/IECEx Exe approved. (2 glands and 1 plug included)
E	euromast® male connector (1 plug included)
M	minifast® male connector (1 plug included)

Table 1. Rosemount 5900S Radar Level Gauge with Parabolic Antenna Ordering Information

Antenna	
1P	Parabolic antenna
Antenna size	
F	20 in./DN 500, Ø=440 mm (17.3 in.)
Antenna material	
S	SST AISI 316L/EN 1.4436
Tank seal	
PF	PTFE with FEP fluoropolymer O-ring
Tank connection	
WE	Welded installation
CL	Clamped/threaded installation
Antenna options	
0	None
V <sup>(13)</sup>	Proof test verification reflector

**Options (include with selected model number)**

Safety certificate	
QT <sup>(14)</sup>	IEC 61508 certificate and FMEDA-data (printed copy)
Calibration certificate	
Q4	Calibration certificate (printed copy)
S4	Witnessed calibration certificate (witnessed by factory selected accredited third party)
Material traceability certificate	
Q8	Antenna material traceability certification per EN 10204 3.1
Overfill protection approval	
U1 <sup>(15)</sup>	TÜV/DIBt WHG approval for overfill protection
U2	SVTI approval for overfill protection (Switzerland)
Tag plate	
ST	Engraved SST tag plate
Extended warranty	
WR3	3-year limited warranty
WR5	5-year limited warranty
<b>Typical model number: 5900S P S F F I5 L 2 A 1 1P F S PF WE 0 Q4</b>	

1. Requires Redundancy code 2 and Rosemount 2410 Tank Hub with Safety certification (SIS) code 3.
2. Requires Rosemount 2410 Tank Hub with either Analog output 4-20 mA or Relay output code 1 or 2.
3. Not available with Cable entry/Conduit connections code E or M.
4. Required Custody transfer type approval code R or 0.
5. Requires the same Custody transfer type approval code for both the Rosemount 2410 Tank Hub and the Rosemount 5900S Radar Level Gauge.
6. Requires Options code Q4.
7. Requires integral display in Rosemount 2410 or Rosemount 2230 or TankMaster.
8. Requires integral display in Rosemount 2410 or Rosemount 2230 with Custody transfer approval code C or TankMaster.
9. Requires Options code S4.
10. Requires Hazardous location certification code I1.
11. Requires integral display in Rosemount 2410 or Rosemount 2230 with Custody transfer approval code L or TankMaster.
12. Requires integral display in Rosemount 2410 or Rosemount 2230 with Custody transfer approval code N or TankMaster.
13. Not available with Options code U1.
14. Requires Safety certification (SIS) code 3 or S.
15. Requires one or more relay outputs in the Rosemount 2410 Tank Hub.

## Rosemount 5900S Radar Level Gauge with horn antenna



Rosemount 5900S with horn antenna is a non-contact radar level gauge. It is designed for easy installation on fixed roofs tanks, with smaller nozzles, down to 200 mm (8 in.).

- Measures on a variety of products except asphalt or similar for which the parabolic antenna is recommended
- Custody transfer accuracy according to OIML R85:2008
- Certified SIL 2 and SIL 3 capable according to IEC 61508
- 2-in-1 functionality available for redundant level measurement
- Communicates via a 2-wire, low voltage Tankbus for easy and safe installation
- Installation normally with tank in service

**Table 2. Rosemount 5900S Radar Level Gauge with Horn Antenna Ordering Information**

Model	Product description
5900S	Radar Level Gauge
<b>Performance class</b>	
P	Premium: ±0.5 mm (0.020 in.) instrument accuracy
<b>Safety certification (SIS)</b>	
3 <sup>(1)</sup>	Certified IEC 61508 SIL 3 capable
S <sup>(2)</sup>	Certified IEC 61508 SIL 2 capable
F	None. Ready for upgrade of Safety certification (SIS)
0	None
<b>Redundancy</b>	
2	2-in-1: Dual independent radar level gauge electronics
F	None. Ready for upgrade to 2-in-1
1	None. Single radar level gauge electronics
<b>Tankbus: Power and communication</b>	
F	Bus powered 2-wire FOUNDATION Fieldbus (IEC 61158)
<b>Hazardous location certification</b>	
I1	ATEX Intrinsic Safety
I2	INMETRO Intrinsic Safety (Brazil)
I4 <sup>(3)</sup>	TIIS Intrinsic Safety (Japan)



**Table 2. Rosemount 5900S Radar Level Gauge with Horn Antenna Ordering Information**

I5	FM-US Intrinsic Safety
I6	FM-Canada Intrinsic Safety
I7	IECEX Intrinsic Safety
IM	Technical Regulations Customs Union (EAC) Intrinsic Safety (Russia)
IP <sup>(4)</sup>	KC Intrinsic Safety (South Korea)
NA	None
<b>Custody transfer type approval<sup>(5)</sup></b>	
R <sup>(6)(7)</sup>	OIML R85 edition 2008
A <sup>(6)(7)</sup>	CMI (Czech Republic)
B <sup>(6)(7)</sup>	NMI (Australia)
C <sup>(6)(8)</sup>	PTB Eich (Germany)
E <sup>(6)(7)</sup>	TJA (Estonia)
G <sup>(6)(7)</sup>	GUM (Poland)
I <sup>(7)(9)</sup>	Ministero (Italy)
K <sup>(6)(7)(10)</sup>	GOST (Kazakhstan)
L <sup>(9)(11)</sup>	LNE (France)
M <sup>(7)(9)</sup>	BMS (Belgium)
N <sup>(9)(12)</sup>	NMi (The Netherlands)
Q <sup>(6)(7)</sup>	IPQ (Portugal)
S <sup>(6)(7)(10)</sup>	GOST (Russia)
W <sup>(6)(7)</sup>	METAS (Switzerland)
Y <sup>(6)(7)</sup>	Justervesenet (Norway)
0	None
<b>Level measurement method</b>	
1	10 GHz FMCW radar technology
2	10 GHz FMCW radar technology for the US market
<b>Housing</b>	
A	Standard enclosure, polyurethane-covered aluminum. IP 66/67
<b>Cable entry/Conduit connections</b>	
1	½ - 14 NPT, female thread. (1 plug included)
2	M20 x 1.5 adapters, female thread. (2 adapters and 1 plug included)
G	Metal cable glands (½ - 14 NPT). Min. temperature -20 °C (-4 °F). ATEX/IECEX Exe approved. (2 glands and 1 plug included)
E	eurofast male connector (1 plug included)
M	minifast male connector (1 plug included)

**Table 2. Rosemount 5900S Radar Level Gauge with Horn Antenna Ordering Information**

<b>Antenna</b>	
1H	Horn antenna
<b>Antenna size</b>	
8	8 in. / DN 200, Ø=175 mm (6.9 in.)
<b>Antenna material</b>	
S	SST AISI 316/316L and SST EN 1.4401/1.4404
<b>Tank seal</b>	
PV	PTFE with Viton® fluoroelastomer O-ring
<b>Tank connection</b>	
<b>ANSI Hole Pattern (SST AISI 316/316 L) – Flat Face</b>	
8A	8 in. Class 150
8Z	8 in. Class 150, inclined 4 degrees
<b>EN Hole Pattern (SST EN 1.4401/1.4404) – Flat Face</b>	
LA	DN 200/PN 10
LZ	DN 200/PN 10, inclined 4 degrees
<b>Antenna options</b>	
0	None

**Options (include with selected model number)**

<b>Safety certificate</b>	
QT <sup>(13)</sup>	IEC 61508 certificate and FMEDA-data (printed copy)
<b>Calibration certificate</b>	
Q4	Calibration certificate (printed copy)
S4	Witnessed calibration certificate (witnessed by factory selected accredited third party)
<b>Material traceability certificate</b>	
Q8	Antenna material traceability certification per EN 10204 3.1
<b>Overfill protection approval</b>	
U1 <sup>(14)</sup>	TÜV/DIBt WHG approval for overfill protection
U2	SVTI approval for overfill protection (Switzerland)
<b>Tag plate</b>	
ST	Engraved SST tag plate

**Table 2. Rosemount 5900S Radar Level Gauge with Horn Antenna Ordering Information**

<b>Extended warranty</b>	
WR3	3-year limited warranty
WR5	5-year limited warranty
<b>Typical model number: 5900S P F 2 F I5 R 2 A G 1H 8 S PV 8Z 0 ST</b>	

1. Requires Redundancy code 2 and Rosemount 2410 Tank Hub with Safety certification (SIS) code 3.
2. Requires Rosemount 2410 Tank Hub with either Analog output 4-20 mA or Relay output code 1 or 2.
3. Not available with Cable entry/Conduit connections code E or M.
4. Required Custody transfer type approval code R or 0.
5. Requires the same Custody transfer type approval code for both the Rosemount 2410 Tank Hub and the Rosemount 5900S Radar Level Gauge.
6. Requires Options code Q4.
7. Requires integral display in Rosemount 2410 or Rosemount 2230 or TankMaster.
8. Requires integral display in Rosemount 2410 or Rosemount 2230 with Custody transfer approval code C or TankMaster.
9. Requires Options code S4.
10. Requires Hazardous location certification code I1.
11. Requires integral display in Rosemount 2410 or Rosemount 2230 with Custody transfer approval code L or TankMaster.
12. Requires integral display in Rosemount 2410 or Rosemount 2230 with Custody transfer approval code N or TankMaster.
13. Requires Safety certification (SIS) code 3 or S.
14. Requires one or more relay outputs in the Rosemount 2410 Tank Hub.

## Rosemount 5900S Radar Level Gauge with still-pipe array antenna



The Rosemount 5900S with array antenna is a premium non-contact radar level gauge for still-pipe measurement, available in two versions, fixed and hinged hatch. Typical applications are crude oil tanks with floating roofs and gasoline/product tanks with or without inner floating roofs.

- Suitable for crude oil, gasoline or similar products
- Custody transfer accuracy according to OIML R85:2008
- Certified SIL 2 and SIL 3 capable according to IEC 61508
- 2-in-1 functionality available for redundant level measurement
- Tolerant against rust and product deposits inside the pipe, using Low Loss mode
- Communicates via a 2-wire, low voltage Tankbus for easy and safe installation
- Hinged hatch version enables easier product sampling and hand-dips
- Installation normally with tank in service

**Table 3. Rosemount 5900S Radar Level Gauge with Still-Pipe Array Antenna Ordering Information**

Model	Product description
5900S	Radar Level Gauge
<b>Performance class</b>	
P	Premium: ±0.5 mm (0.020 in.) instrument accuracy
<b>Safety certification (SIS)</b>	
3 <sup>(1)</sup>	Certified IEC 61508 SIL 3 capable
S <sup>(2)</sup>	Certified IEC 61508 SIL 2 capable
F	None. Ready for upgrade of Safety certification (SIS)
0	None
<b>Redundancy</b>	
2	2-in-1; Dual independent radar level gauge electronics
F	None. Ready for upgrade to 2-in-1
1	None. Single radar level gauge electronics
<b>Tankbus: Power and communication</b>	
F	Bus powered 2-wire FOUNDATION Fieldbus (IEC 61158)
<b>Hazardous location certification</b>	
I1	ATEX Intrinsic Safety

**Table 3. Rosemount 5900S Radar Level Gauge with Still-Pipe Array Antenna Ordering Information**

I2	INMETRO Intrinsic Safety (Brazil)
I4 <sup>(3)</sup>	TIIS Intrinsic Safety (Japan)
I5	FM-US Intrinsic Safety
I6	FM-Canada Intrinsic Safety
I7	IECEx Intrinsic Safety
IM	Technical Regulations Customs Union (EAC) Intrinsic Safety (Russia)
IP <sup>(4)</sup>	KC Intrinsic Safety (South Korea)
NA	None
<b>Custody transfer type approval<sup>(5)</sup></b>	
R <sup>(6)(7)</sup>	OIML R85 edition 2008
A <sup>(6)(7)</sup>	CMI (Czech Republic)
B <sup>(6)(7)</sup>	NMI (Australia)
C <sup>(6)(8)</sup>	PTB Eich (Germany)
E <sup>(6)(7)</sup>	TJA (Estonia)
G <sup>(6)(7)</sup>	GUM (Poland)
I <sup>(7)(9)</sup>	Ministero (Italy)
K <sup>(6)(7)(10)</sup>	GOST (Kazakhstan)
L <sup>(9)(11)</sup>	LNE (France)
M <sup>(7)(9)</sup>	BMS (Belgium)
N <sup>(9)(12)</sup>	NMi (The Netherlands)
Q <sup>(6)(7)</sup>	IPQ (Portugal)
S <sup>(6)(7)(10)</sup>	GOST (Russia)
W <sup>(6)(7)</sup>	METAS (Switzerland)
Y <sup>(6)(7)</sup>	Justervesenet (Norway)
0	None
<b>Level measurement method</b>	
1	10 GHz FMCW radar technology
2	10 GHz FMCW radar technology for the US market
<b>Housing</b>	
A	Standard enclosure, polyurethane-covered aluminum. IP 66/67
<b>Cable entry/Conduit connections</b>	
1	½ - 14 NPT, female thread. (1 plug included)
2	M20 x 1.5 adapters, female thread. (2 adapters and 1 plug included)
G	Metal cable glands (½ - 14 NPT). Min. temperature -20 °C (-4 °F). ATEX / IECEx Exe approved. (2 glands and 1 plug included)

**Table 3. Rosemount 5900S Radar Level Gauge with Still-Pipe Array Antenna Ordering Information**

E	eurofast male connector (1 plug included)
M	minifast male connector (1 plug included)
<b>Antenna</b>	
1A	Still-pipe array antenna
<b>Antenna size</b>	
5	5 in./DN 125, Ø=120 mm (4.7 in.)
6	6 in./DN 150, Ø=145 mm (5.7 in.)
8	8 in./DN 200, Ø=189 mm (7.4 in.)
A	10 in./DN 250, Ø=243 mm (9.8 in.)
B	12 in./DN 300, Ø=293 mm (11.8 in.)
<b>Antenna material</b>	
S	SST (AISI 316L / EN 1.4404) and PPS (polyphenylene sulfide)
<b>Tank seal</b>	
FF	Fixed flange installation with fluorosilicone O-ring
HH	Integrated hatch installation with fluorosilicone O-ring (direct access to pipe with hand gauge)
<b>Tank connection</b>	
<b>ANSI Hole Pattern (SST AISI 316/316 L) – Flat Face</b>	
5A	5 in. Class 150
6A	6 in. Class 150
8A	8 in. Class 150
AA	10 in. Class 150
BA	12 in. Class 150
<b>EN Hole Pattern (SST EN 1.4404) – Flat Face</b>	
KA	DN 150 PN 16
LA	DN 200 PN 10
MB	DN 250 PN 16
<b>Antenna options</b>	
0	None
C	Clamp flange in galvanized steel (for still-pipes without a flange). Same size as tank connection
V <sup>(13)(14)</sup>	Proof test verification reflector (size equal to Tank connection)

**Table 3. Rosemount 5900S Radar Level Gauge with Still-Pipe Array Antenna Ordering Information****Options (include with selected model number)**

<b>Safety certificate</b>	
QT <sup>(15)</sup>	IEC 61508 certificate and FMEDA-data (printed copy)
<b>Calibration certificate</b>	
Q4	Calibration certificate (printed copy)
S4	Witnessed calibration certificate (witnessed by factory selected accredited third party)
<b>Material traceability certificate</b>	
Q8	Antenna material traceability certification per EN 10204 3.1
<b>Overfill protection approval</b>	
U1 <sup>(16)</sup>	TÜV/DIBt WHG approval for overfill protection
U2	SVTI approval for overfill protection (Switzerland)
<b>Tag plate</b>	
ST	Engraved SST tag plate
<b>Extended warranty</b>	
WR3	3-year limited warranty
WR5	5-year limited warranty
<b>Typical model number: 5900S P F 1 F I5 R 2 A 1 1A 5 S FF AA C Q4</b>	

1. Requires Redundancy code 2 and Rosemount 2410 Tank Hub with Safety certification (SIS) code 3.
2. Requires Rosemount 2410 Tank Hub with either Analog output 4-20 mA or Relay output code 1 or 2.
3. Not available with Cable entry/Conduit connections code E or M.
4. Required Custody transfer type approval code R or 0.
5. Requires the same Custody transfer type approval code for both the Rosemount 2410 Tank Hub and the Rosemount 5900S Radar Level Gauge.
6. Requires Options code Q4.
7. Requires integral display in Rosemount 2410 or Rosemount 2230 or TankMaster.
8. Requires integral display in Rosemount 2410 or Rosemount 2230 with Custody transfer approval code C or TankMaster.
9. Requires Options code S4.
10. Requires Hazardous location certification code I1.
11. Requires integral display in Rosemount 2410 or Rosemount 2230 with Custody transfer approval code L or TankMaster.
12. Requires integral display in Rosemount 2410 or Rosemount 2230 with Custody transfer approval code N or TankMaster.
13. Requires Custody transfer type approval code 0 or R, and Antenna size 6 or 8.
14. Not available with Options code U1.
15. Requires Safety Certification (SIS) code S or 3.
16. Requires one or more relay outputs in the Rosemount 2410 Tank Hub.

## Rosemount 5900S Radar Level Gauge with LPG/LNG antenna



The Rosemount 5900S with LPG/LNG antenna is a premium non-contact radar level gauge for measurement on pressurized or cryogenic liquefied gas. Radar signals are transmitted inside the still-pipe which enables the gauge to have a sufficiently strong echo even under turbulent conditions, such as a boiling surface.

- Custody transfer accuracy according to OIML R85:2008
- Certified SIL 2 and SIL 3 capable according to IEC 61508
- 2-in-1 functionality available for redundant level measurement
- Reference device function enables measurement verification with the tank in service
- Communicates via a 2-wire, low voltage Tankbus for easy and safe installation
- Built-in pressure sensor for vapor compensation gives best measurement performance
- Integrated ball valve

**Table 4. Rosemount 5900S Radar Level Gauge with LPG/LNG Antenna Ordering Information**

Model	Product description
5900S	Radar Level Gauge
<b>Performance class</b>	
P	Premium: ±0.5 mm (0.020 in.) instrument accuracy
<b>Safety certification (SIS)</b>	
3 <sup>(1)</sup>	Certified IEC 61508 SIL 3 capable
S <sup>(2)</sup>	Certified IEC 61508 SIL 2 capable
F	None. Ready for upgrade to Safety certification (SIS)
0	None
<b>Redundancy</b>	
2	2-in-1; Dual independent radar level gauge electronics
F	None. Ready for upgrade to 2-in-1
1	None. Single radar level gauge electronics
<b>Tankbus: Power and communication</b>	
F	Bus powered 2-wire FOUNDATION Fieldbus (IEC 61158)
<b>Hazardous location certification</b>	
I1	ATEX Intrinsic Safety



**Table 4. Rosemount 5900S Radar Level Gauge with LPG/LNG Antenna Ordering Information**

I2	INMETRO Intrinsic Safety (Brazil)
I4 <sup>(3)</sup>	TIIS Intrinsic Safety (Japan)
I5	FM-US Intrinsic Safety
I6	FM-Canada Intrinsic Safety
I7	IECEx Intrinsic Safety
IM	Technical Regulations Customs Union (EAC) Intrinsic Safety
IP <sup>(4)</sup>	KC Intrinsic Safety (South Korea)
NA	None
<b>Custody transfer type approval<sup>(5)</sup></b>	
R <sup>(6)(7)</sup>	OIML R85 edition 2008
A <sup>(6)(7)</sup>	CMI (Czech Republic)
B <sup>(6)(7)</sup>	NMI (Australia)
C <sup>(6)(8)</sup>	PTB Eich (Germany)
E <sup>(6)(7)</sup>	TJA (Estonia)
G <sup>(6)(7)</sup>	GUM (Poland)
I <sup>(7)(9)</sup>	Ministero (Italy)
K <sup>(6)(7)(10)</sup>	GOST (Kazakhstan)
L <sup>(9)(11)</sup>	LNE (France)
M <sup>(7)(9)</sup>	BMS (Belgium)
N <sup>(9)(12)</sup>	NMi (The Netherlands)
Q <sup>(6)(7)</sup>	IPQ (Portugal)
S <sup>(6)(7)(10)</sup>	GOST (Russia)
W <sup>(6)(7)</sup>	METAS (Switzerland)
Y <sup>(6)(7)</sup>	Justervesenet (Norway)
0	None
<b>Level measurement method</b>	
1	10 GHz FMCW radar technology
2	10 GHz FMCW radar technology for the US market
<b>Housing</b>	
A	Standard enclosure, polyurethane-covered aluminum. IP 66/67
<b>Cable entry/Conduit connections</b>	
1	½ - 14 NPT, female thread (1 plug included)
2	M20 x 1.5 adapters, female thread (2 adapters and 1 plug included)
G	Metal cable glands (½ - 14 NPT). Min. temperature -20 °C (-4 °F). ATEX/IECEx Exe approved. (2 glands and 1 plug included)

**Table 4. Rosemount 5900S Radar Level Gauge with LPG/LNG Antenna Ordering Information**

E	eurofast male connector (1 plug included)
M	minifast male connector (1 plug included)
<b>Antenna</b>	
G1	LNG still-pipe antenna (with integrated ball-valve)
G2 <sup>(13)</sup>	LPG still-pipe antenna (with integrated ball-valve and pressure transmitter)
<b>Antenna size</b>	
A	4 in. Schedule 10, Ø=107 mm (4.2 in.)
B	4 in. Schedule 40, Ø=101 mm (4.0 in.)
D	DN 100, Ø=99 mm (3.9 in.)
<b>Antenna material</b>	
S	SST AISI 316/316L and SST EN1.4401/1.4404
<b>Tank seal</b>	
QA	Quartz sealing
<b>Tank connection</b>	
<b>ANSI Flanges (SST AISI 316/316 L) – Raised Face</b>	
1B <sup>(14)(15)</sup>	1.5 in. Class 300
2A <sup>(14)(15)</sup>	2 in. Class 150
2B <sup>(14)(15)</sup>	2 in. Class 300
3A <sup>(14)(15)</sup>	3 in. Class 150
3B <sup>(14)(15)</sup>	3 in. Class 300
4A	4 in. Class 150
4B	4 in. Class 300
6A	6 in. Class 150
6B	6 in. Class 300
8A	8 in. Class 150
8B	8 in. Class 300
<b>Antenna options</b>	
V	Measurement verification kit with 1 verification pin and 1 pipe end deflector kit

**Options (include with selected model number)**

<b>Safety certificate</b>	
QT <sup>(16)</sup>	IEC 61508 certificate and FMEDA-data (printed copy)

**Table 4. Rosemount 5900S Radar Level Gauge with LPG/LNG Antenna Ordering Information**

<b>Calibration certificate</b>	
Q4	Calibration certificate (printed copy)
S4	Witnessed calibration certificate (witnessed by factory selected accredited third party)
<b>Material traceability certificate</b>	
Q8	Antenna material traceability certification per EN 10204 3.1
<b>Overfill protection approval</b>	
U1 <sup>(17)</sup>	TÜV/DIBt WHG approval for overfill protection
U2	SVTI approval for overfill protection (Switzerland)
<b>Tag plate</b>	
ST	Engraved SST tag plate
<b>Hydrostatic pressure test</b>	
P1	Antenna hydrostatic pressure testing
<b>Extended warranty</b>	
WR3	3-year limited warranty
WR5	5-year limited warranty
<b>Typical model number: 5900S P S F F I5 R 2 A 1 G1 B S QA 4B V ST</b>	

- Requires Redundancy code 2 and Rosemount 2410 Tank Hub with Safety certification (SIS) code 3.
- Requires Rosemount 2410 Tank Hub with either Analog output 4-20 mA or Relay output code 1 or 2.
- Not available with Cable entry/Conduit connections code E or M.
- Required Custody transfer type approval code R or 0.
- Requires the same Custody transfer type approval code for both the Rosemount 2410 Tank Hub and the Rosemount 5900S Radar Level Gauge.
- Requires Options code Q4.
- Requires integral display in Rosemount 2410 or Rosemount 2230 or TankMaster.
- Requires integral display in Rosemount 2410 or Rosemount 2230 with Custody transfer approval code C or TankMaster.
- Requires Options code S4.
- Requires Hazardous location certification code I1.
- Requires integral display in Rosemount 2410 or Rosemount 2230 with Custody transfer approval code L or TankMaster.
- Requires integral display in Rosemount 2410 or Rosemount 2230 with Custody transfer approval code N or TankMaster.
- Requires Hazardous location certification code I1, I2, I4, I5, I6, I7, IM or IP.
- Requires Custody transfer type approval code R or 0. Requires Antenna size code A.
- Not available with Safety certification (SIS) code 3.
- Requires Safety Certification (SIS) code S or 3.
- Requires one or more relay outputs in the Rosemount 2410 Tank Hub.

# Specifications

## General

### Instrument accuracy<sup>(1)</sup>

#### Rosemount 5900S standard version

± 0.5 mm (0.020 in.)

#### Rosemount 5900S 2-in-1 version

± 0.5 mm (0.020 in.)<sup>(2)</sup>

### Temperature stability

Typically < ± 0.5 mm (0.020 in.) in -40 to +70 °C (-40 to +158 °F)

### Fieldbus (standard)

FOUNDATION Fieldbus FISCO (Tankbus)

### Update time

New measurement every 0.3 s

### Repeatability

0.2 mm (0.008 in.)

### Maximum level rate

Up to 200 mm/s

### Metrology sealing possibility

Yes

### Installation considerations

See Rosemount 5900S [Reference Manual](#)

## Measurement principle

The FMCW-method (Frequency Modulated Continuous Wave) means that the transmitted radar signal has a linear frequency variation around 10 GHz. The reflection from the liquid surface has a slightly different frequency compared with the signal transmitted from the antenna when the reflection is received. The difference in frequency is directly proportional to the distance between the antenna and the liquid surface, and thereby also the liquid level. This technology enables a very accurate and stable measured value.

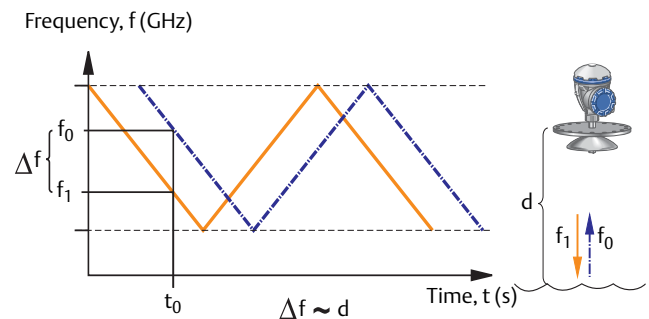

The FMCW-method is based on a radar sweep with varying frequency.

## Communication / Display / Configuration

### Output variables and units

- Level, and ullage: meter, centimeter, millimeter, feet, or inch
- Level rate: meter/second, meter/hour, feet/second, feet/hour, inch/minute
- Signal strength: mV

### Configuration tools

Rosemount TankMaster WinSetup, Field Communicator

1. Instrument accuracy is under reference conditions. Reference conditions are: Measurement in test bench at Rosemount Tank Radar AB in Mölnlycke Sweden. Test bench is calibrated minimum yearly by an accredited laboratory (SP Technical Research Institute of Sweden. Measuring range is up to 30 m (98 ft). Ambient temperature and humidity is close to constant during tests. Total uncertainty in test bench is below 0.15 mm (0.006 in.).

2. Some level offset may be expected on the secondary unit.

## FOUNDATION Fieldbus characteristics

### Polarity sensitive

No

### Quiescent current draw

51 mA

### Lift-off minimum voltage

9.0 VDC

### Device capacitance / inductance

See “Product Certifications” on page 26

### Class (Basic or Link Master)

Link Master (LAS)

### Number of available VCRs

Maximum 20, including one fixed

### Links

Maximum 40

### Minimum slot time / maximum response delay/ minimum intermessage delay

8/5/8

### Blocks and Execution time

Block	Execution time
1 Resource block	N/A
5 Transducer blocks (Level, Register, Adv_Config, Volume, and LPG)	N/A
6 Analog Input (AI)	10 ms
2 Analog Output (AO)	10 ms
1 Proportional/Integral/Derivate (PID)	15 ms
1 Signal Characterizer (SGCR)	10 ms
1 Integrator (INT)	10 ms
1 Arithmetic (ARTH)	10 ms
1 Input Selector (ISEL)	10 ms
1 Control Selector (CS)	10 ms
1 Output Splitter (OS)	10 ms

For more information, see the FOUNDATION Fieldbus Blocks [Manual](#).

### Instantiation

Yes

### Conforming FOUNDATION Fieldbus

ITK 5.2

### PlantWeb™ alert support

Yes

### Action support wizards

Restart measurement, write protect device, factory reset - measurement configuration, start/stop device simulation, set as surface, reset statistics, change all modes, register/remove false echo, refresh echo peaks, pin verification, change vapor pressure, change vapor temperature.

### Advanced diagnostics

Software, memory/database, electronics, internal communication, simulation, level correction, level measurement, ambient temperature, vapor pressure/temperature correction, LPG verification pin, and manual measurement values.

## Electric

### Tankbus cabling

0.5-1.5 mm<sup>2</sup> (AWG 22-16), twisted shielded pairs

### Power supply

FISCO: 9.0 - 17.5 VDC polarity insensitive (for example from Rosemount 2410 Tank Hub)

Entity: 9.0 - 30.0 VDC polarity insensitive

### Bus current draw

50 mA (100 mA for the 2-in-1 version)

### Microwave output power

< 1 mW

## Mechanical

### Housing material & surface treatment

Polyurethane-coated die-cast aluminum

### Cable entry (connection/glands)

Two ½ - 14 NPT entries for cable glands or conduits. One metal plug to seal any unused port is enclosed in the transmitter delivery.

Optional:

- M20 x 1.5 conduit / cable adapter
- Cable glands in metal (½ - 14 NPT)
- 4-pin male eurofast connector or A size Mini 4-pin male minifast connector

### Total weight

Transmitter head	Weight
Rosemount 5900S single version	5.1 kg (11.2 lbs)
Rosemount 5900S 2-in-1 version	5.4 kg (11.9 lbs)

Transmitter head with antenna	Weight
Rosemount 5900S with horn antenna	Appr. 12 kg (26 lbs)
Rosemount 5900S with parabolic antenna	Appr. 17 kg (37 lbs)
Rosemount 5900S with still-pipe array antenna	Appr. 13.5-24 kg (30-53 lbs)
Rosemount 5900S with LPG/LNG antenna, 6-in. 150 psi	Appr. 30 kg (66 lbs)
Rosemount 5900S with LPG/LNG antenna, 6-in. 300 psi	40 kg (88 lbs)

### Antennas

The Rosemount 5900S antennas have a drip-off design which for some versions also include inclined polished PTFE surfaces. Condensation on the antenna is minimized, and the radar signal remains strong. This results in maintenance free operation, high accuracy and reliability. There is always a suitable antenna for every tank type, tank opening and application.

### Transmitter head

The same transmitter head is used for all Rosemount 5900S antenna types, minimizing spare part requirements:

- The dual compartment transmitter housing, with electronics and cabling separated, can be replaced without opening the tank
- It is protected against lightning, moisture/rain, and has a surface protection against sulphur and salt spray atmospheres
- Electronics consists of one or two encapsulated units. The 2-in-1 solution has duplicate, galvanically isolated electronic units in the same housing

To achieve highest precision, Rosemount 5900S has an on-line adjustment of transmitter frequency. It uses a crystal oscillator to control the output frequency. This is one of the reasons why there is no need for gauge re-calibration.

## Environment

### Ambient operating temperature

-40 to +70 °C (-40 to +158 °F). Minimum start-up temperature is -50 °C (-58 °F)

### Storage temperature

-50 to +85 °C (-58 to +185 °F)

### Humidity

0-100% relative humidity

### Ingress protection

IP 66/67 and Nema 4X

### Vibration resistance

IEC 60770-1 level 1 and IACS UR E10 test 7

### Telecommunication

Compliance with:

- FCC 15B Class A, and 15C
- R&TTE (EU directive 99/5/EC) ETSI EN 302372; EN 50371
- IC (RSS210-5)

### Electromagnetic compatibility

- EMC (EU directive 2004/108/EC) EN 61326-1; EN 61326-3-1
- OIML R85:2008

**Transient / built-in lightning protection**

According to IEC 61000-4-5, level 2 kV line to ground. Complies with IEEE 587 Category B transient protection and IEEE 472 surge protection.

**Low Voltage Directive (LVD)**

LVD (EU directive 2006/95/EC) EN/IEC 61010-1

**Rosemount 5900S SIL 2 version (SIS option code S)****Rosemount 5900S standard version****Built-in Tankbus terminator**

Yes (to be connected if required)

**Daisy chain possibility**

Yes

**Rosemount 5900S 2-in-1 version****Separation**

Galvanically separated gauge electronics, and shared antenna for the two units

**Wiring**

Separated or common

**Tank hub connection**

- Connection of both units to one hub, or
- Separate connection of units to two different hubs

**Built-in Tankbus terminator**

Single Tankbus connection: Yes (to be connected if required).

Dual Tankbus connection: Possible to terminate the primary Tankbus.

**Daisy chain possibility**

Yes

**Rosemount 5900S SIL 3 version (SIS option code 3)****Measuring range**

1.2 to 30 m (3.9 to 100 ft) below flange.

**Separation**

Galvanically separated gauge electronics, and shared antenna

**Built-in Tankbus terminator**

No

**Daisy chain possibility**

Yes

**Electric properties for intrinsically safe alarm signal**

12.5 VDC, 1-2 mA for normal condition (no alarm)

**Wiring**

- Additional separate 2-wire cable for alarm or
- A single cable incorporating two 2-wire cables (alarm and level)

For cable specification, see [page 22](#)

**Rosemount 5900S with parabolic antenna****Operating temperature in tank**

Max. +230 °C (+445 °F)

**Measuring range**

0.8 to 30 m (2.6 to 100 ft) below flange.

Possibility to measure with extended range<sup>(1)</sup>: 0.5 to 50 m (1.6 to 164 ft).

**Pressure range**

Clamped/threaded: -0.2 to 0.2 bar (-2.9 to 2.9 psig)

Welded: -0.2 to 10 bar (-2.9 to 145 psig)

**Material exposed to tank atmosphere**

Antenna: material corresponds to AISI 316/316L and EN 1.4401 / 1.4404.

Sealing: PTFE

O-ring: FEP fluoropolymer

1. Accuracy may be affected by installation considerations when using extended measuring range. Please consult your local representative.

**Antenna dimension**

440 mm (17 in.)

**Manway size and installation**

500 mm (20-in.) opening.

The parabolic antenna is installed on the manway cover by using the flange ball. It is designed for easy adjustment of the antenna inclination and orientation within the specified limits.

The flexible flange ball can be installed on both horizontal or inclined manways without any special arrangements.

**Rosemount 5900S with horn antenna****Operating temperature in tank**

Max. +230 °C (+445 °F)

**Measuring range**

0.8 to 20 m (2.6 to 65 ft) below flange.

Possibility to measure with extended range<sup>(1)</sup>: 0.5 to 30 m (1.6 to 100 ft).

**Pressure range**

-0.2 to 2 bar (-2.9 to 29 psig)

**Material exposed to tank atmosphere**

Antenna and flange: material corresponds to AISI 316/316L and EN 1.4401 /1.4404.

Sealing: PTFE

O-ring: Viton fluoroelastomer

**Antenna dimension**

175 mm (7 in.)

**Nozzle diameter**

Minimum 200 mm (8 in.)

**Tank connection**

The flange can be horizontal or 4° inclined for installation close to the tank wall.

The horizontal flange is used when highest accuracy and reliability is required. The 4° inclined version can be used to maintain high accuracy when the gauge is installed close to the tank wall.

**Rosemount 5900S with still-pipe array antenna****Operating temperature in tank**

-40 to 120 °C (-40 to 248 °F)

**Measuring range**

0.8 to 30 m (2.6 to 100 ft) below flange.

Possibility to measure with extended range<sup>(1)</sup>: 0.5 to 40 m (1.6 to 130 ft).

**Pressure range**

Fixed version: -0.2 to 2 bar (-2.9 to 29 psig) at 20 °C (68 °F).

Hinged hatch version: -0.2 to 0.5 bar (-2.9 to 7.2 psig) for 5 to 8-in. pipes.

-0.2 to 0.25 bar (-2.9 to 3.6 psig) for 10 and 12-in. pipes.

**Material exposed to tank atmosphere**

Antenna: Polyphenylenesulphide (PPS)

Sealing: PTFE

O-ring: Fluorosilicone

Flange: material corresponds to AISI 316/316L and EN 1.4401 /1.4404

**Still-pipe dimensions**

5-, 6-, 8-, 10- or 12 in.

**Tank connection**

5 in. hole pattern according to ANSI 5 in. Class 150

6 in. hole pattern according to ANSI 6 in.

Class 150 / DN 150 PN 16

8 in. hole pattern according to ANSI 8 in.

Class 150 / DN 200 PN 10

10 in. hole pattern according to ANSI 10 in.

Class 150 / DN 250 PN 16

12 in. hole pattern according to ANSI 12 in. Class 150

1. Accuracy may be affected by installation considerations when using extended measuring range. Please consult your local representative.



## Low Loss Mode

To get the accuracy, required for custody transfer bulk liquid storage applications, the antenna uses Low Loss Mode technology, invented for Rosemount Tank Gauging products, to transmit radar waves in the still-pipe center.

This virtually eliminates signal and accuracy degradation due to rust and product deposits inside the still-pipe.

## Rosemount 5900S with LPG/LNG antenna

### Operating temperature at ball valve

-55 to 90 °C (-67 to 194 °F)

### Operating temperature in tank

-170 to 90 °C (-274 to 194 °F)

### Measuring range

1.2 to 30 m (3.9 to 100 ft) below flange.

Possibility to measure with extended range<sup>(1)</sup>: 0.8 to 60 m (2.6 to 200 ft).

### Pressure range

-1 to 25 bar (-14.5 to 365 psig).

Note! Flanges may have higher pressure rating than 25 bar, but maximum tank pressure is still 25 bar.

### Pressure sensor (option)

Rosemount 2051. It is available with various hazardous location certifications, see [“Product Certifications Rosemount 2051” on page 31](#).

For more information see the Rosemount 2051 [Product Data Sheet](#).

### Material exposed to tank atmosphere

Antenna and flange: material corresponds to AISI 316/316L and EN 1.4401 /1.4404.

Sealing: Quartz and PTFE

### Still-pipe dimension compatibility

Antenna choices for 4-in. sch. 10, 4-in. sch 40, or 100 mm (99 mm inner diameter) still-pipe dimensions

## Flange size and rating

4 in. class 150/300

6 in. class 150/300

8 in. class 150/300

## Pressure seal

The pressure seal includes a double-block function, consisting of a quartz/ceramic window and a fire-proof ball valve. A pressure sensor enables correction due to vapor for best measurement performance.

## Verification possibility

A patented reference device function enables measurement verification with the tank in service. A verification pin mounted in a still-pipe hole, and a deflection plate with a verification ring at the lower still-pipe end provide reference echoes at fixed pre-defined distances.

1. Accuracy may be affected by installation considerations when using extended measuring range. Please consult your local representative.

# Product Certifications

Rev 6.0

## European Directive Information

The most recent revision of the EU Declaration of Conformity can be found at [Emerson.com/Rosemount](http://Emerson.com/Rosemount).

## Ordinary Location Certification

As standard, the transmitter has been examined and tested to determine that the design meets the basic electrical, mechanical, and fire protection requirements by a nationally recognized test laboratory (NRTL) as accredited by the Federal Occupational Safety and Health Administration (OSHA).

## Telecommunication compliance

### FCC

This device complies with Part 15C of the FCC Rules. Operation is subject to the following two conditions: (1) This device may not cause interference, and (2) this device must accept any interference received, including interference that may cause undesired operation.

Certificate: K8C5900

### IC

This device complies with RSS210-5.

Certificate: 2827A-5900

### R&TTE

This device complies with ETSI EN 302 372 and EN 62479. EU directive 99/5/EC.

## OIML R85:2008 Accuracy Certification

The OIML metrology certificate, issued by the SP Technical Research Institute of Sweden, covers the Rosemount Tank Gauging system, including the level gauges equipped with different antennas.

Certificate number is R85/2008-SE-11.01.

## National Metrological Approvals

Other national legal custody transfer certifications like PTB, NMI etc are available.

## CE-mark

93/68/EEC: complies with applicable EU directives (EMC, ATEX,LVD, and R&TTE). Based on the low emitted effects from the gauges (below 0.1 mW) compared to limits given by the Rec. 1999/519/EC, no additional measures are needed.

## Ordinary Location Certification

Complies with FM 3810:2005 and CSA: C22.2 No. 1010.1

## SIL Certification

The SIL safety certificate, issued by exida in Switzerland, includes the SIL alarm channel within the 5900S radar level gauge and the 2410 Tank Hub. Both units are SIL 2 and SIL 3 capable according to IEC 61508, parts 1-7.

Certificate numbers: ROS 1312 032 C001, ROS 1312 032 C004 and ROS 1312 032 C005.

## German WHG Certification

The certificate for the 5900S radar level gauge and the 2410 Tank Hub is issued by DIBt (Deutsches Institut für Bautechnik) according to the German WHG regulations for overfill prevention. It is based on technical evaluation and testing conducted by TÜV NORD CERT GmbH.

Certificate number is Z-65.16-500.

## Installing Equipment in North America

The US National Electrical Code® (NEC) and the Canadian Electrical Code (CEC) permit the use of Division marked equipment in Zones and Zone marked equipment in Divisions. The markings must be suitable for the area classification, gas, and temperature class. This information is clearly defined in the respective codes.

## North America

### 15 USA Intrinsic Safety

Certificate: 3035466

Standards: FM Class 3600 – 2011, FM Class 3610 – 2010, FM Class 3810 – 2005, ANSI/NEMA 250 – 2003, ANSI/IEC 60529 – 2004, ANSI/ISA 60079-0 – 2013, ANSI/ISA 60079-11 – 2013, ANSI/ISA 60079-26 – 2011

Markings: IS/I,II,III/1/ABCDEFG/T4 Ta = -50°C to 80°C - 9240040-917; Entity; FISCO  
 \*I/O/1/AEx ia IIC T4 Ta = -50°C to 80°C - 9240040-917; Entity; FISCO  
 DIP/II,III/1/EFG/T5 Ta = -50°C to 80°C  
 Type 4X; IP66; IP67

	Ui	Ii	Pi	Ci	Li
<b>Entity parameters</b>	30 V	300 mA	1.3 W	1.1 nF	1.5 µH
<b>FISCO parameters</b>	17.5V	380 mA	5.32 W	1.1 nF	1.5 µH

#### Special Conditions for Safe Use (X):

1. Parabolic and Array antennas with plastic surfaces and the surface of the painted housing may, under certain extreme conditions, generate an ignition-capable level of electrostatic. Appropriate measures must be taken to prevent electrostatic discharge.
2. Class I, Zone 0/1 notation: For installation in Zone classified locations, the Rosemount 5900 Radar Level Gauge was evaluated so that an [ib] associated apparatus can connect to it restricting the installation of the electronics to a Zone 1 location while still allowing the antenna to enter a Zone 0 location.

### 16 Canada Intrinsic Safety

Certificate: 3035466C

Standards: CSA-C22.2 No. 157-92 - 1992 (2012), CSA-C22.2 No. 1010-1 – 2004 (2009), CSA-C22.2 No. 25-1966 - 1992 (2009), CSA-C22.2 No. 60529-05 - 2005 (2010), CSA-C22.2 No. E60079-0 - 2011, CSA-C22.2 No. E60079-11 - 2011, CSA-C22.2 No 94 - 2011

Markings: IS/I,II,III/1/ABCDEFG/T4 Ta = -50°C to 80°C - 9240040-917; Entity; FISCO  
 I/O/Ex ia IIC T4 Ta = -50°C to 80°C - 9240040-917; Entity; FISCO  
 DIP/II,III/1/EFG/T5 Ta = -50°C to 80°C  
 Type 4X; IP66; IP67

	Ui	Ii	Pi	Ci	Li
<b>Entity parameters</b>	30 V	300 mA	1.3 W	1.1 nF	1.5 µH
<b>FISCO parameters</b>	17.5V	380 mA	5.32 W	1.1 nF	1.5 µH

#### Special Conditions for Safe Use (X):

1. Parabolic and Array antennas with plastic surfaces and the surface of the painted housing may, under certain extreme conditions, generate an ignition-capable level of electrostatic. Appropriate measures must be taken to prevent electrostatic discharge.

## Europe

### 11 ATEX Intrinsic Safety

Certificate: FM09ATEX0057X

Standards: EN 60079-0:2012, EN 60079-11:2012, EN 60079-26:2007, EN 60529:2013

Markings:  II 1/2 G Ex ia IIC T4 Ta = -50°C to 80°C; IP66, IP67\*  
 II 1/2 G Ex ia IIC T4 Ta = -50°C to 80°C; FISCO; IP66, IP67\*

	Ui	Ii	Pi	Ci	Li
<b>Entity parameters</b>	30 V	300 mA	1.3 W	1.1 nF	1.5 µH
<b>FISCO parameters</b>	17.5V	380 mA	5.32 W	1.1 nF	1.5 µH

#### Special Conditions for Safe Use (X):

1. The enclosure contains aluminum and is considered to present a potential risk of ignition by impact or friction. Care must be taken during installation and use to prevent impact or friction.
2. Parabolic and Array antennas with plastic surfaces may, under certain extreme conditions, generate an ignition-capable level of electrostatic charge for IIC applications. Therefore, when these antennas are used in Category 1G, Group IIC, appropriate measures must be taken to prevent electrostatic discharge.
3. \*Category 1/2 notation: The Rosemount 5900 Radar Level Gauge was evaluated so that an [ib] associated apparatus can connect to it restricting the installation of the electronics to a Zone 1 location while still allowing the antenna to enter a Zone 0 location

## International

### 17 IECEx Intrinsic Safety

Certificate: IECEx FMG 09.0009X

Standards: IEC 60079-0:2011, IEC 60079-11:2011, IEC 60079-26:2006

Markings: FISCO: Ex ia IIC Ga/Gb; IP66, IP67  
Entity: Ex ia IIC Ga/Gb; IP66, IP67  
Tamb = -50°C to +80°C

	Ui	Ii	Pi	Ci	Li
<b>Entity parameters</b>	30 V	300 mA	1.3 W	1.1 nF	1.5 μH
<b>FISCO parameters</b>	17.5V	380 mA	5.32 W	1.1 nF	1.5 μH

#### Special Conditions for Safe Use (X):

- The enclosure contains aluminum and is considered to present a potential risk of ignition by impact or friction. Care must be taken during installation and use to prevent impact or friction.
- Parabolic and Array antennas with plastic surfaces may, under certain extreme conditions, generate an ignition-capable level of electrostatic charge for IIC applications. Therefore, when these antennas are used in Category 1G, Group IIC, appropriate measures must be taken to prevent electrostatic discharge.
- \*Category 1/2 notation: The Rosemount 5900 Radar Level Gauge was evaluated so that an [ib] associated apparatus can connect to it restricting the installation of the electronics to a Zone 1 location while still allowing the antenna to enter a Zone 0 location.

## Brazil

### 12 INMETRO Intrinsic Safety

Certificate: IEx 11.0073X

Standards: ABNT NBR IEC 60079-0:2013, ABNT NBR IEC 60079-11:2013

Markings: Ex ia IIC T4 Ga/Gb (Entity)  
Ex ia IIC T4 Ga/Gb (FISCO)  
Tamb: -50 °C to + 80 °C  
IP66/IP67

	Ui	Ii	Pi	Ci	Li
<b>Entity parameters</b>	30 V	300 mA	1.3 W	1.1 nF	1.5 μH
<b>FISCO parameters</b>	17.5V	380 mA	5.32 W	1.1 nF	1.5 μH

#### Special Conditions for Safe Use (X):

- See certificate for special conditions.

## China

### 13 China Intrinsic Safety

Certificate: GYJ16.1251X

Standards: GB 3836.1 – 2010, GB 3836.4 – 2010, GB 3836.20 – 2010

Markings: Ex ia IIC T4 Ga

	Ui	Ii	Pi	Ci	Li
<b>Entity parameters</b>	30 V	300 mA	1.3 W	1.1 nF	1.5 μH
<b>FISCO parameters</b>	17.5V	380 mA	5.32 W	1.1 nF	1.5 μH

#### Special Conditions for Safe Use (X):

- See certificate for special conditions.

## Technical Regulations Customs Union (EAC)

### 1M EAC Intrinsic Safety

Certificate: RU C-SE.AA87.B.00346

Markings: Ga/Gb Ex ia IIC T4 X  
Tamb: -50 °C to + 80 °C  
IP66/IP67

	Ui	Ii	Pi	Ci	Li
<b>Entity parameters</b>	30 V	300 mA	1.3 W	1.1 nF	1.5 μH
<b>FISCO parameters</b>	17.5V	380 mA	5.32 W	1.1 nF	1.5 μH

#### Special Conditions for Safe Use (X):

- See certificate for special conditions.

## Japan

### 14 Japan Intrinsic Safety

Certificate: TC20972

Markings: Ex ib IIB T4  
-20°C ≤ Ta ≤ +60°C

	Ui	Ii	Pi	Ci	Li
<b>Entity parameters</b>	30 V	300 mA	1.3 W	1.1 nF	1.5 μH
<b>FISCO parameters</b>	17.5V	380 mA	5.32 W	1.1 nF	1.5 μH

## Republic of Korea

**IP** Korea Intrinsic Safety  
 Certificate: 14-KB4BO-0573X  
 Markings: Ex ia IIC T4 Ga/Gb  
 (-50°C ≤ Ta ≤ +80°C)

	Ui	Ii	Pi	Ci	Li
<b>Entity parameters</b>	30 V	300 mA	1.3 W	1.1 nF	1.5 μH
<b>FISCO parameters</b>	17.5V	380 mA	5.32 W	1.1 nF	1.5 μH

### Special Conditions for Safe Use (X):

1. See certificate for special conditions.

## Additional Certifications

### Safety Certification (SIS)

- 3 Functional Safety  
 Certificate: ROS 1312032 C001  
 SIL 3 2-in-1 (1oo2) option (SIS-relays)  
 Standards: IEC 61508:2010 Parts 1-7
- 2 Functional Safety  
 Certificate: ROS 1312032 C002  
 SIL 2 1-in-1 (1oo1) option (SIS-relays)  
 Standards: IEC 61508:2010 Parts 1-7  
 Certificate: ROS 1312032 C003  
 SIL 2 2-in-1 (1oo1) option (SIS-relays)  
 Standards: IEC 61508:2010 Parts 1-7
- S Functional Safety  
 Certificate: ROS 1312032 C004  
 SIL 2 1-in-1 (1oo1) option, with 4-20mA or K1/K2 relay  
 Standards: IEC 61508:2010 Parts 1-7  
 Certificate: ROS 1312032 C005  
 SIL 2 2-in-1 (1oo1) option, with 4-20mA or K1/K2 relay  
 Standards: IEC 61508:2010 Parts 1-7

### India Intrinsic Safety

Certificate: P349859/1  
 Markings: Ex ia IIC Ga/Gb

### Australia Custody Transfer

Certificate: No 5/1/7  
 Standards: Regulation 60 : National Measurement Regulations 1999

### Belgium Custody Transfer

BMS Certificate: NR. P6.0.014.01-B-12

### China Custody Transfer

CPA Pattern Approval  
 Certificate: 2012-L134 (5900S), 2015-L206 (5900C)

### Croatia Custody Transfer

Certificate: 558-02-01\_01-15-2

### Czech Republic Custody Transfer

Certificate: 0111-CS-C022-10

### Estonia Custody Transfer

Certificate: TJA 6.13-3\_15.09.11

### France Custody Transfer

Certificate: No. LNE-24609

### Germany Custody Transfer

Certificate: PTB-1.5-4058175 (Raptor system)

### India Custody Transfer

Certificate: IND/13/12/191

### Indonesia Custody Transfer

Certificate: DITJEN MIGAS CT approval 26.10.2010

### Italy Custody Transfer

Certificate: 183349 (Raptor system)

### Malaysia Custody Transfer

Certificate: ATS 09-11

### Netherlands Custody Transfer

NMI Certificate: TC7982

### Norway Custody Transfer

Certificate: No. N-11-7146

### Poland Custody Transfer

Certificate: ZT-7 2013

### Portugal Custody Transfer

Certificate: P12\_101.12\_31

### Serbia Custody Transfer

Certificate: 393-7\_0-01-2088

### South Africa Custody Transfer

Certificate: SAEx S11-065

### Switzerland Custody Transfer

Certificate: Zulassungszertifikat CH-L-11127-01

**Russia Custody Transfer**

GOST Pattern Approval  
 Certificate: SE.C.29.004.A No. 46866 (5900S)  
 SE.C.29.004.A No. 49065 (Raptor system)

**Kazakhstan Custody Transfer**

GOST Pattern Approval  
 Certificate: KZ.02.02.04023-2014 No.10795 (5900S)  
 KZ.02.02.04018-2014 No.10790 (Raptor system)

**OIML Custody Transfer**

Certificate: R85-2008-SE-11.01

**Special Conditions for Safe Use (X):**

1. When the thread adapter or blanking plug is used with an enclosure in type of protection increased safety “e” the entry thread shall be suitably sealed in order to maintain the ingress protection rating (IP) of the enclosure. See certificate for special conditions.
2. The blanking plug shall not be used with an adapter.
3. Blanking Plug and Threaded Adapter shall be either NPT or Metric thread forms. G½ thread forms are only acceptable for existing (legacy) equipment installations.

**Conduit plugs and adapters**

IECEx Flameproof and Increased Safety

Certificate: IECEx FMG 13.0032X  
 Standards: IEC60079-0:2011, IEC60079-1:2007-04,  
 IEC60079-7:2006-07  
 Markings: Ex de IIC Gb

ATEX Flameproof and Increased Safety

Certificate: FM13ATEX0076X  
 Standards: EN60079-0:2012, EN60079-1:2007,  
 IEC60079-7:2007  
 Markings:  II 2 G Ex de IIC Gb

**Conduit Plug Thread Sizes**

Thread	Identification Mark
M20 x 1.5	M20
½ - 14 NPT	½ NPT

**Thread Adapter Thread Sizes**

Male Thread	Identification Mark
M20 x 1.5 – 6g	M20
½ - 14 NPT	½ - 14 NPT
¾ - 14 NPT	¾ - 14 NPT
Female Thread	Identification Mark
M20 x 1.5 – 6H	M20
½ - 14 NPT	½ - 14 NPT
G1/2	G1/2

# Product Certifications Rosemount 2051

Extract from Rosemount 2051 Product Certifications Rev: 1.5

## North America

### IE USA FISCO

Certificate: FM16US0231X

Standards: FM Class 3600 – 2011, FM Class 3610 – 2010, FM Class 3611 – 2004, FM Class 3810 – 2005

Markings: IS CL I, DIV 1, GP A, B, C, D when connected per Rosemount drawing 02051-1009 (-50°C ≤ Ta ≤ +60°C); Type 4x

#### Specific Conditions of Use:

1. The Model 2051 transmitter housing contains aluminum and is considered a potential risk of ignition by impact or friction. Care must be taken into account during installation and use to prevent impact and friction.

### IF Canada Intrinsic Safety

Certificate: 2041384

Standards: CSA Std. C22.2 No. 142 - M1987, CSA Std. C22.2 No. 213 - M1987, CSA Std. C22.2 No. 157 - 92, CSA Std. C22.2 No. 213 - M1987, ANSI/ISA 12.27.01 – 2003, CAN/CSA-E60079-0:07, CAN/CSA-E60079-11:02

Markings: Intrinsically safe for Class I, Division 1, Groups A, B, C, and D when connected in accordance with Rosemount drawing 02051-1008. Ex ia IIC T3C. Single Seal. Enclosure Type 4X

## Europe

### IA ATEX FISCO

Certificate: Baseefa08ATEX0129X

Standards: EN60079-0:2012, EN60079-11:2012

Markings:  II 1 G Ex ia IIC T4 Ga (-60°C ≤ Ta ≤ +60°C)

	Ui	Ii	Pi	Ci	Li
FISCO parameters	17.5V	380 mA	5.32 W	0 μF	0 mH

#### Special Conditions for Safe Use (X):

1. If the equipment is fitted with an optional 90V transient suppressor, it is incapable of withstanding the 500V isolation from earth test and this must be taken into account during installation.
2. The enclosure may be made of aluminum alloy and given a protective polyurethane paint finish; however care should be taken to protect it from impact and abrasion when located in Zone 0.

## International

### IG IECEX FISCO

Certificate: IECEXBAS08.0045X

Standards: IEC60079-0:2011, IEC60079-11:2011

Markings: Ex ia IIC T4 Ga (-60°C ≤ Ta ≤ +60°C)

	Ui	Ii	Pi	Ci	Li
FISCO parameters	17.5V	380 mA	5.32 W	0 nF	0 μH

#### Special Conditions for Safe Use (X):

1. If the equipment is fitted with an optional 90V transient suppressor, it is incapable of withstanding the 500V isolation from earth test and this must be taken into account during installation.
2. The enclosure may be made of aluminum alloy and given a protective polyurethane paint finish; however care should be taken to protect it from impact and abrasion when located in Zone 0.

# Dimensional Drawings

Figure 1. Rosemount 5900S with Parabolic Antenna Dimensions

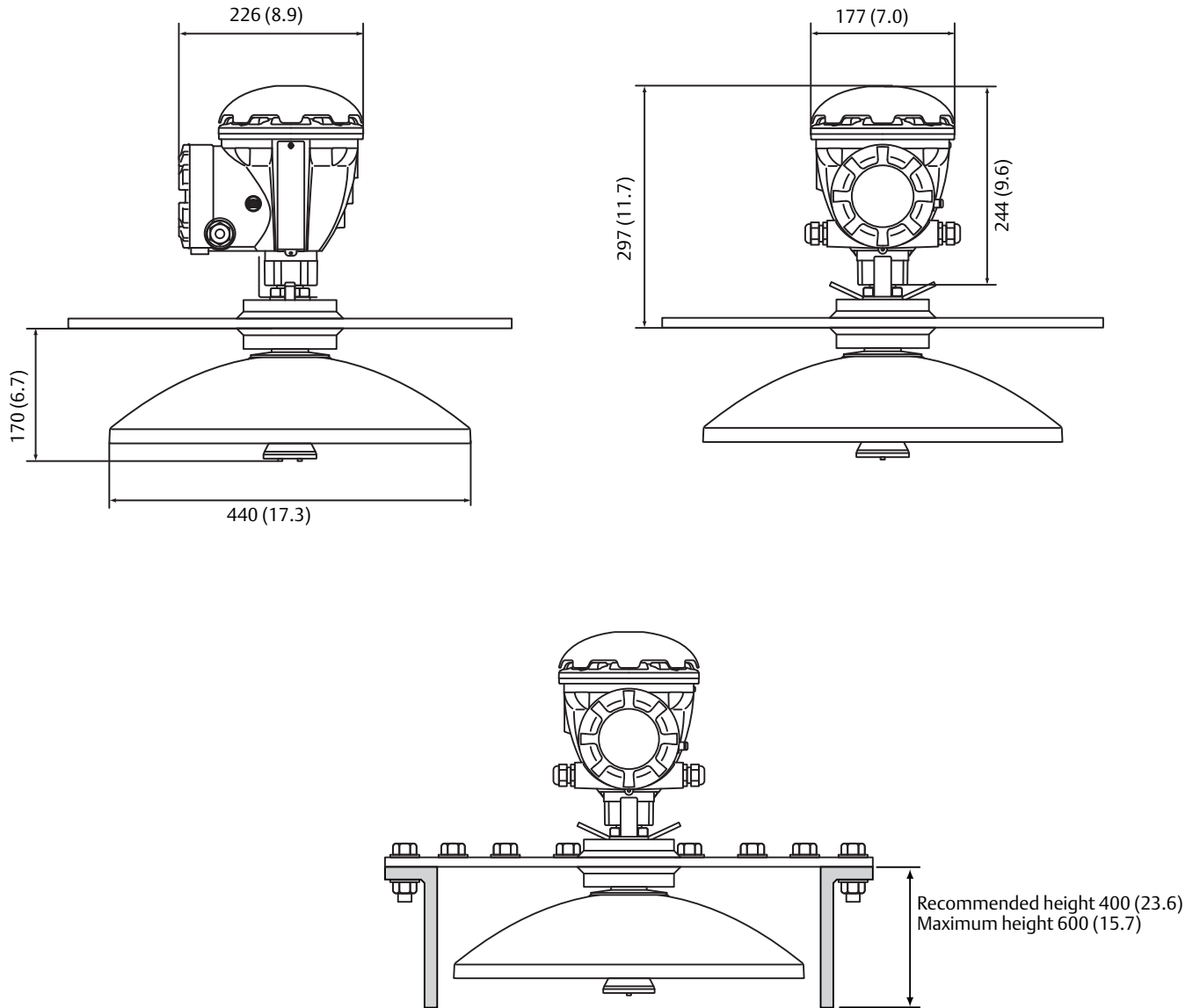

Dimensions are in millimeters (inches).



**Figure 2. Rosemount 5900S with Horn Antenna Dimensions**

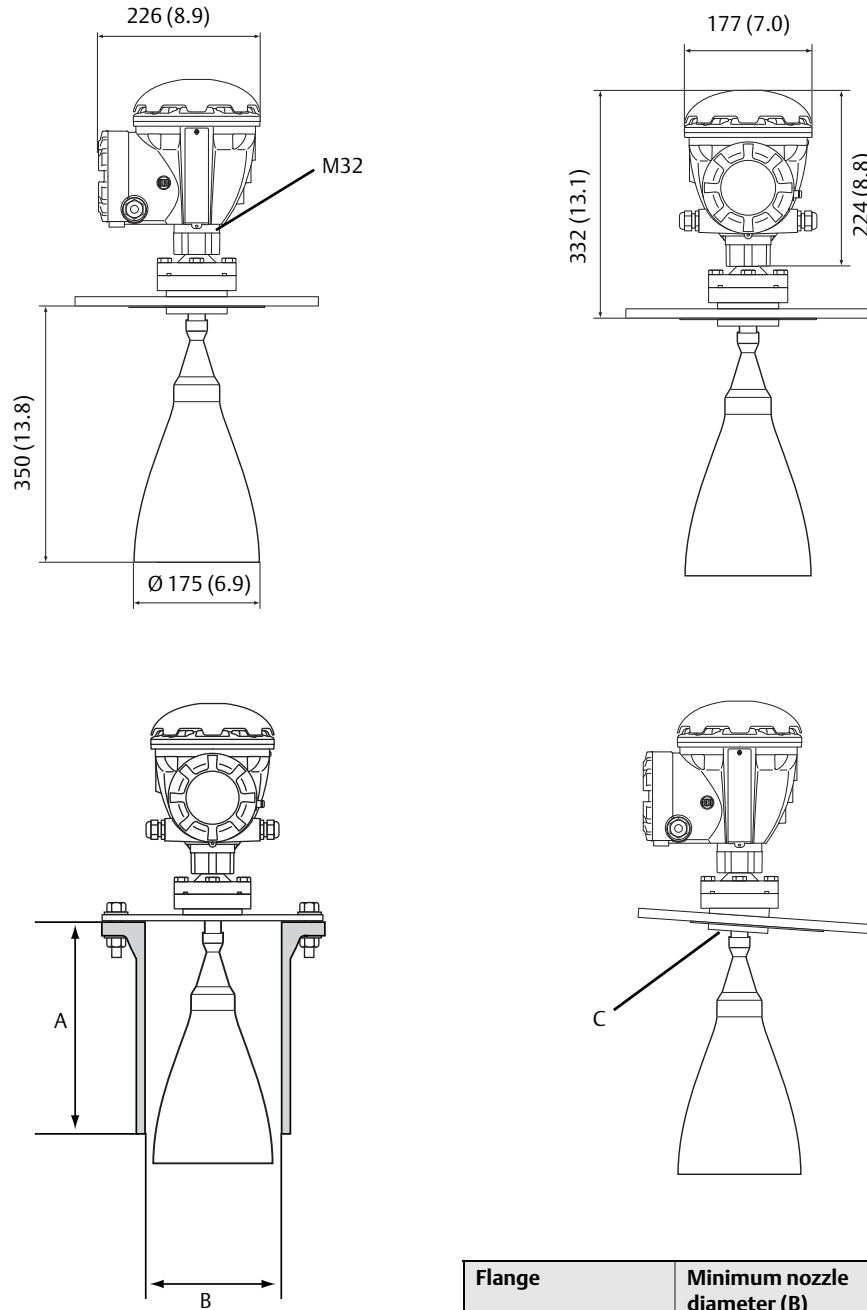

Flange	Minimum nozzle diameter (B)	Maximum nozzle height (A)
Horizontal flange	180 mm (7.1 in.)	330 mm (13.0 in.)
4° flange	185 mm (7.3 in.)	330 mm (13.0 in.)

- A. Maximum nozzle height
- B. Minimum nozzle diameter
- C. 4° inclined flange

Dimensions are in millimeters (inches).

Figure 3. Rosemount 5900S with Still-Pipe Array Antenna Dimensions

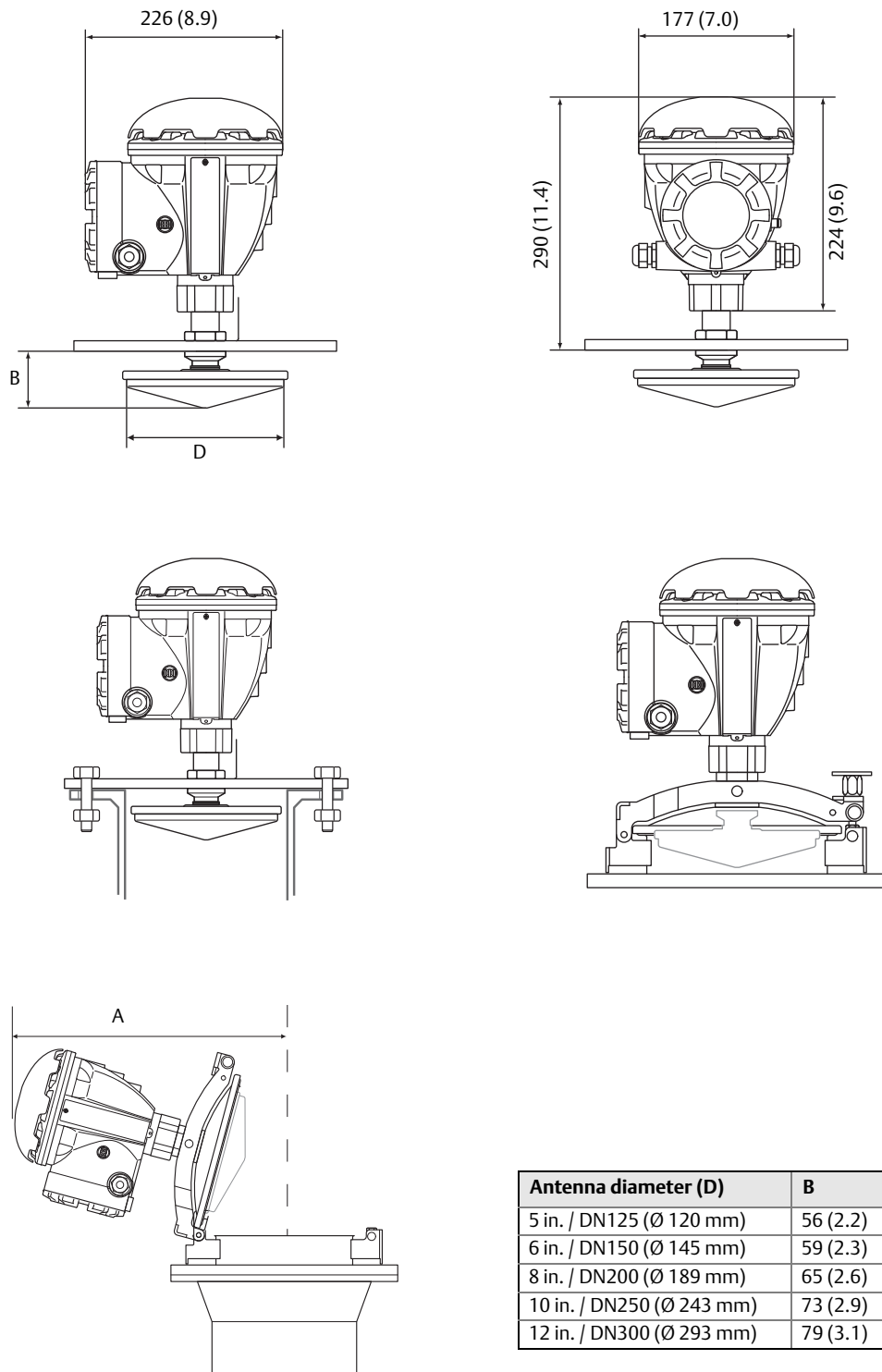

Antenna diameter (D)	B	A
5 in. / DN125 (Ø 120 mm)	56 (2.2)	470 (18.5)
6 in. / DN150 (Ø 145 mm)	59 (2.3)	470 (18.5)
8 in. / DN200 (Ø 189 mm)	65 (2.6)	480 (18.9)
10 in. / DN250 (Ø 243 mm)	73 (2.9)	490 (19.3)
12 in. / DN300 (Ø 293 mm)	79 (3.1)	490 (19.3)

Dimensions are in millimeters (inches).

**Figure 4. Rosemount 5900S with LPG/LNG Antenna Dimensions**

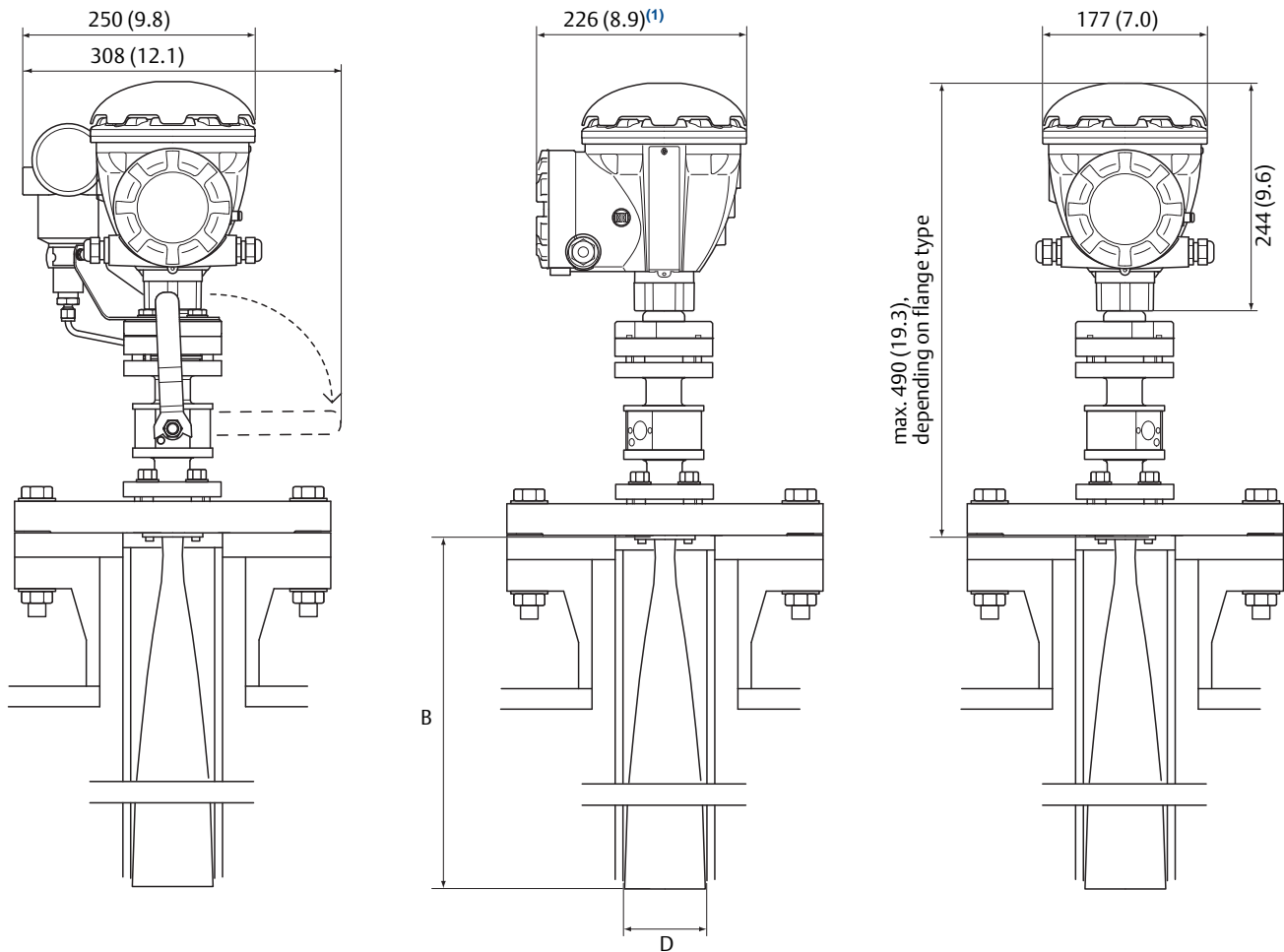

1. 302 (11.9) with pressure transmitter option

Antenna diameter (D)	B
4 in. Sch10 (Ø 107 mm)	752 (29.6)
4 in. Sch40 (Ø 101 mm)	534 (21.0)
DN100 (Ø 99 mm)	502 (19.8)

Dimensions are in millimeters (inches).